

Алматы (7273)495-231
Ангарск (3955)60-70-56
Архангельск (8182)63-90-72
Астрахань (8512)99-46-04
Барнаул (3852)73-04-60
Белгород (4722)40-23-64
Благовещенск (4162)22-76-07
Брянск (4832)59-03-52
Владивосток (423)249-28-31
Владикавказ (8672)28-90-48
Владимир (4922)49-43-18
Волгоград (844)278-03-48
Вологда (8172)26-41-59
Воронеж (473)204-51-73
Екатеринбург (343)384-55-89
Иваново (4932)77-34-06
Ижевск (3412)26-03-58
Иркутск (395)279-98-46
Казань (843)206-01-48

Калининград (4012)72-03-81
Калуга (4842)92-23-67
Кемерово (3842)65-04-62
Киров (8332)68-02-04
Коломна (4966)23-41-49
Кострома (4942)77-07-48
Краснодар (861)203-40-90
Красноярск (391)204-63-61
Курган (3522)50-90-47
Курск (4712)77-13-04
Липецк (4742)52-20-81
Магнитогорск (3519)55-03-13
Москва (495)268-04-70
Мурманск (8152)59-64-93
Набережные Челны (8552)20-53-41
Нижегород (831)429-08-12
Новокузнецк (3843)20-46-81
Новосибирск (383)227-86-73
Ноябрьск (3496)41-32-12

Омск (3812)21-46-40
Орел (4862)44-53-42
Оренбург (3532)37-68-04
Пенза (8412)22-31-16
Пермь (342)205-81-47
Петрозаводск (8142)55-98-37
Псков (8112)59-10-37
Ростов-на-Дону (863)308-18-15
Рязань (4912)46-61-64
Самара (846)206-03-16
Санкт-Петербург (812)309-46-40
Саранск (8342)22-96-24
Саратов (845)249-38-78
Севастополь (8692)22-31-93
Симферополь (3652)67-13-56
Смоленск (4812)29-41-54
Сочи (862)225-72-31
Ставрополь (8652)20-65-13
Сургут (3462)77-98-35

Сыктывкар (8212)25-95-17
Тамбов (4752)50-40-97
Тверь (4822)63-31-35
Тольятти (8482)63-91-07
Томск (3822)98-41-53
Тула (4872)33-79-87
Тюмень (3452)66-21-18
Улан-Удэ (3012)59-97-51
Ульяновск (8422)24-23-59
Уфа (347)229-48-12
Хабаровск (4212)92-98-04
Чебоксары (8352)28-53-07
Челябинск (351)202-03-61
Череповец (8202)49-02-64
Чита (3022)38-34-83
Якутск (4112)23-90-97
Ярославль (4852)69-52-93

Россия +7(495)268-04-70

Казахстан +7(7172)727-132

Киргизия +996(312)96-26-47

<https://opti.nt-rt.ru> || opti@nt-rt.ru

КОМБИНИРОВАННЫЕ ПРИБОРЫ

SHD 200



1.1 Control unit for 4...20 mA / HART field devices

The SHD 200 is a unit for control and monitoring of process parameters in various industry applications. It is suitable to be connecting to all loop-powered field devices with 4...20 mA current output and/or HART[®] communication. The SHD 200 exceeds the functionality of an ordinary display. It features different customer-specific measurement pages displaying up to 4 different values for detailed process monitoring (incl. trend graph and summary page). For improved process control, the control unit comes with two freely programmable relays for status, system alert and limit switch as well as a second current output for any HART[®] variable (e.g. temperature in pH and conductivity measurements). In addition, it offers the possibility of commissioning OPTIBAR pressure transmitters and OPTIWAVE level transmitters. Connecting a HART[®] handheld, the SHD 200 provides access to all sensor functions including calibration.



Figure 1-1: SHD 200 plastic housing

- 1 High-brightness LEDs for NAMUR NE 107 status signalisation
- 2 Display
- 3 Operation keys
- 4 Cable glands

Highlights

- Control unit for 4...20 mA/HART[®] field devices
- 2 wire, loop-powered device
- Second 4...20 mA current output for any HART[®] variable
- 2 configurable relays for status output, limit switch, system alarm, cleaning control, error current or alert functionality acc. to USP<645>
- Different user-configurable measuring pages for all 4...20 mA and HART[®] signals, trend graph and summary page
- Commissioning of OPTIBAR pressure transmitters and OPTIWAVE level transmitters
- Full access to all sensor functions including calibration possible by connecting a HART[®] handheld
- Status signalisation by 5 LEDs according to NAMUR NE 107
- Robust plastic or aluminium housing (IP66/67)

2.1 Technical data

- *The following data is provided for general applications. If you require data that is more relevant to your specific application, please contact us or your local sales office.*
- *Additional information (certificates, special tools, software,...) and complete product documentation can be downloaded free of charge from the website (Downloadcenter).*

Measuring system

Measuring principle	The measuring principle depends on the used field device(s), for further information refer to the field device manual(s).
Measuring range	The measuring range depends on the used field device(s), for further information refer to the field device manual(s).

Design

Construction	A typical measuring system consists of: <ul style="list-style-type: none"> • SHD 200 • HART® capable field device
Communication protocol	≥ HART®

Display and user interface

Graphic display	LC display 256 x 128 pixel
Operating elements	4 push buttons for operator control of the unit without opening the housing.
Operating menu	The operation menu consists of: Measuring mode: 6 pages (5 measurement pages and 1 status page) Menu mode: variety of main and submenus that allows to customise the device according to the demands of the measuring point.
Operating and display languages	English, German, French, Italian, Spanish, simplified Chinese
Units	HART® units and customer specific units

Operating conditions

Temperature	
Ambient	-20...+70°C / -4...+158°F
	Note: the manufacturer strongly recommends to protect the unit from external heat sources such as direct sunlight as higher temperatures reduce the life cycle of all electronic components!
Storage	-30...+70°C / -22...+158°F
Altitude	≤ 2000 m / 6561.68

Other conditions

Humidity	RH4...100% rH (IEC 60721-3-4:1995 Class 4K4)
Ingress protection acc. to IEC 60529:	IP66/ IP67

Installation conditions

Weight	Approx. 413 g / 0.91 lb for plastic housing Approx. 855 g / 1.89 lb for aluminium housing
Installation	Wall mounting; assure a vertical mounting orientation Wall or pipe mounting with weather protection cover

Materials

Housing	Aluminium Plastic (Polycarbonate)
Cable glands	3xM16x1.5 2xM12x1.5 Material: Polyamid

Electrical connections

Power supply	20...30 VDC, loop powered from 4...20 mA signal input; Voltage drop max. 4V at 4 mA and 2V at 20 mA
System requirements	250 Ω loop resistance for HART [®] communication. Note: In most Ex isolation amplifiers the 250 Ohm resistor is already integrated.
Current output	12...30 VDC; 4...20 mA signal output (passive)
Relays	<p>Two solid state relays working as status output, limit switch, system alarm, cleaning control, error current or alert functionality acc. to US 645.</p> <ul style="list-style-type: none"> • The relay contacts are electrically isolated from each other and from all other circuits • The output stages of the status outputs/limit switches behave like relay contacts • Possible conditions: NO (normally open) or NC (normally closed) <p>Connection values:</p> <ul style="list-style-type: none"> • Maximum voltage = 30 V • Maximum load current = 75 mA up to 55°C and 50 mA above 55°C

Approvals and certifications

CE	
The device meets the essential requirements of the EU directives. The CE marking indicates the conformity of the product with the union legislation applying to the product and providing for CE marking.	
For full information of the EU directives and standards and the approved certifications, please refer to the EU declaration on the website of the manufacturer.	
Hazardous areas	
ATEX	ATEX II 2 G Ex ia IIC T4 Gb
IECEX	IECEX ia IIC T4 Gb
QPS	QPS Ex ia IIC T4 Gb / Class I, Zone 1 AEx ia IIC T4 Gb
UKEX	UKEX II 2 G Ex ia IIC T4 Gb
Other approvals and standards	
NAMUR recommendation	NE 6, NE 21, NE 43, NE 53, NE 107
Shock resistance	IEC 60721-3-4 class 4M4
Vibration resistance	IEC 60721-3-4 class 4M4
	IEC 61298-3 low vibration control room

2.2 Dimensions

Plastic housing

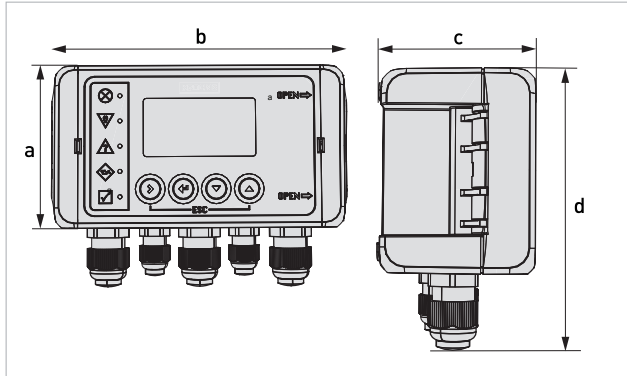

Figure 2-1: Dimensions plastic housing

	Dimensions [mm]				Weight [g]
	a	b	c	d	
Wall mounted	80	151	60	105	413

Table 2-1: Dimensions plastic housing in mm

	Dimensions [inch]				Weight [pound]
	a	b	c	d	
Wall mounted	3.15	5.94	2.36	4.13	0.91

Table 2-2: Dimensions plastic housing in inch

Aluminium housing

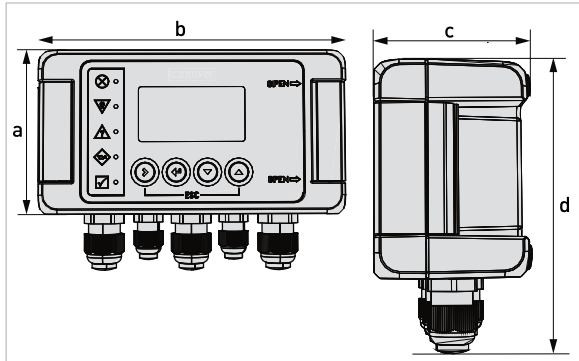

Figure 2-2: Dimensions aluminium housing

	Dimensions [mm]				Weight [g]
	a	b	c	d	
Wall mounted	86	159	60	111	855

Table 2-3: Dimensions aluminium housing in mm

	Dimensions [inch]				Weight [pound]
	a	b	c	d	
Wall mounted	3.39	6.26	2.36	4.37	1.89

Table 2-4: Dimensions aluminium housing in inch

3.1 General notes on installation

Inspect the packaging carefully for damages or signs of rough handling. Report damage to the carrier and to the local office of the manufacturer.

Do a check of the packing list to make sure that you have all the elements given in the order.

Look at the device nameplate to ensure that the device is delivered according to your order. Check for the correct supply voltage printed on the nameplate.

3.2 Intended use

For devices used in hazardous areas, additional safety notes apply; please refer to the Ex documentation.

Responsibility for the use of the measuring devices with regard to suitability, intended use and corrosion resistance of the used materials against the measured fluid lies solely with the operator.

If the device is not used according to the operating conditions (refer to chapter "Technical data"), the intended protection could be affected.

This device is a Group 1, Class A device as specified within CISPR11. It is intended for use in industrial environment. There may be potential difficulties in ensuring electromagnetic compatibility in other environments, due to conducted as well as radiated disturbances.

The manufacturer is not liable for any damage resulting from improper use or use for other than the intended purpose.

The SHD 200 is a control unit for 4...20 mA/HART[®] field devices. The intended use is process control by using the relays, the second current output and the NAMUR NE 107 signalisation by LEDs for the HART[®] parameters of the connected field device. The device has been constructed for indoor and outdoor use below the maximum altitude of 2000 m / 6562 ft.

3.3 Pre-installation requirements

Always note the following items to ensure a proper and safe installation:

- *Make sure that there is adequate space to the sides.*
- *Protect the device from direct sunlight.*
- *The device installed in control cabinets require adequate cooling, e.g. by fan or heat exchanger.*
- *Do not expose the device to intense vibration.*
- *Use assembly materials and tools in compliance with the applicable occupational health and safety directives (assembly materials and tools are not part of the scope of delivery).*
- *Do not make any mechanical modifications to the device. This can result in the loss of proper functionality, as well as the rights under the device warranty.*
- *The device must not be heated by radiated heat (e.g. exposure to the sun) to a electronics housing surface temperature above the maximum permissible ambient temperature. If it is necessary to prevent damage from heat sources, a heat protection (e.g. sun shade) has to be installed.*

The device must be suitable for the temperature specified (including chemical resistance).

Assembly materials and tools are not part of the delivery. Use the assembly materials and tools in compliance with the applicable occupational health and safety directives.

3.4 Opening the housing

Clean and grease all threads each time you open the housing. Use only resin-free and acid-free grease. Before closing the cover, ensure that the housing gasket is properly fitted, clean and undamaged.

All installation works on the electrical connections and mounting require to open the housing:

Opening the plastic housing

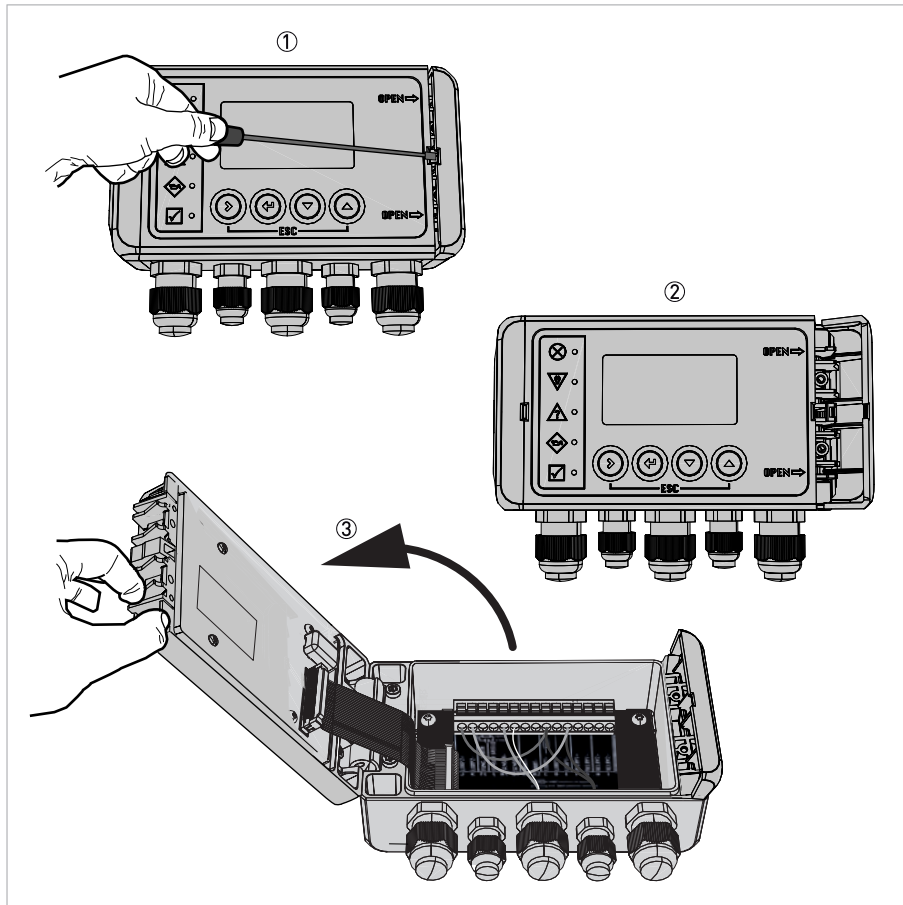

Figure 3-1: Opening the plastic housing

- Put a small flat tool (e.g. screwdriver) into the right hinge lock and open the device 1.
- Lift up the housing 2.
- i Now you have access to the electronic compartment and the possibility to mount the device on a wall.

Opening the aluminium housing

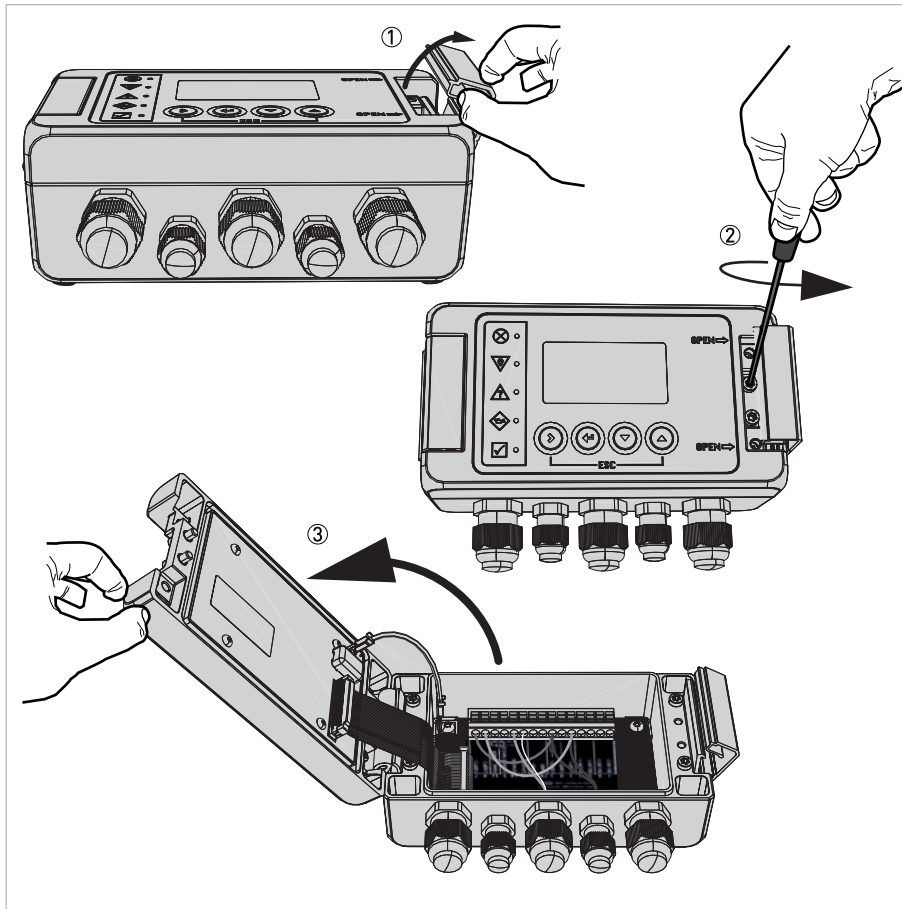

Figure 3-2: Opening the aluminium housing

- Pull only the right hinge lock the side 1.
 - Loosen the 2 torx screws (TX20) with a torx screwdriver 2.
 - Lift up the housing 3.
- i Now you have access to the electronic compartment and the possibility to mount the device on a wall.
- For closing the housing again, use the 2 torx screws with a torque of 1,5 Nm.

3.5 Wall mounting

Always note the following items to ensure a proper and safe installation:

- Make sure that there is adequate space to the sides.
- The device must not be heated by radiated heat (e.g. exposure to the sun) to a electronics housing surface temperature above the maximum permissible ambient temperature. If it is necessary to prevent damage from heat sources, a heat protection (e.g. sun shade) has to be installed.
- Units installed in control cabinets require adequate cooling, e.g. by fan or heat exchanger.
- Do not expose the unit to intense vibration.
- Use assembly materials and tools in compliance with the applicable occupational health and safety directives (assembly materials and tools are not part of the scope of delivery).

Installation, assembly, start-up and maintenance may only be performed by appropriately trained personnel. The regional occupational health and safety directives must always be observed.

A mounting system with a minimum load force of 0.1 kN (for example FISCHER type UX10) suitable for the background has to be applied.

3.5.1 Plastic housing

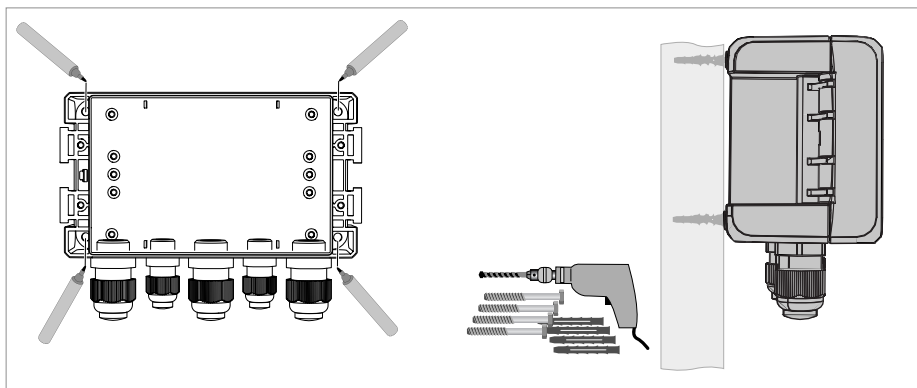

Figure 3-3: Wall mounting of the plastic housing

- 1 Mark the holes with a suitable pen 1.
- 2 Drill the 4 holes and fasten the device securely to the wall 2.

For outdoor mounting, we recommend the optional weather protection cover XGSH010000 for wall and pipe mounting. For more flexibility and convenient mounting, we recommend wall mounting brackets XGSH010020 for plastic housing.

3.5.2 Aluminium housing

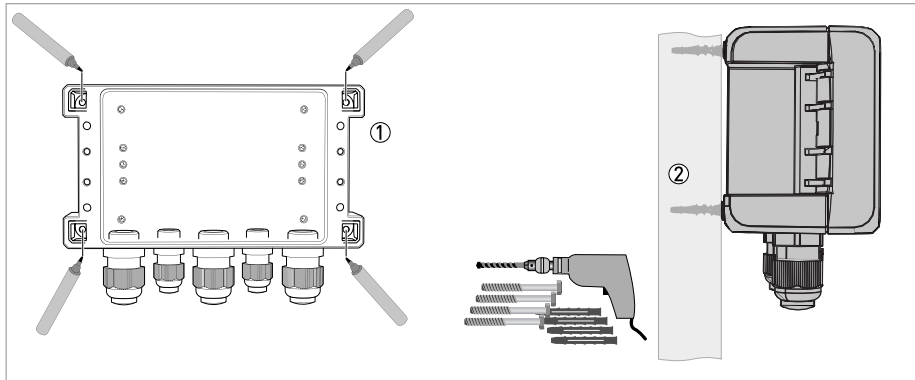

Figure 3-4: Wall mounting of the aluminium housing

- 1 Mark the holes with a suitable pen 1.
- 2 Drill the 4 holes and fasten the device securely to the wall 2.

For outdoor mounting, we recommend the optional weather protection cover XGSH010000 for wall and pipe mounting. For more flexibility and convenient mounting, we recommend wall mounting brackets XGSH010030 for aluminium housing.

4 ELECTRICAL CONNECTIONS

4.1 Connection diagram overview

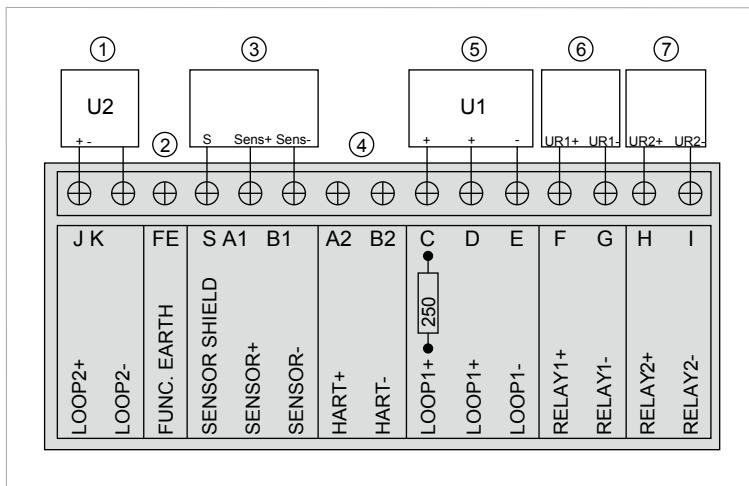

Figure 4-1: Connection diagram overview

- 1 Terminals for loop 2
- 2 Terminal for functional earth
- 3 Terminals for sensor connection
- 4 Terminals for external HART-Modem / external HART-adaptor
- 5 Terminals for loop 1: Connect D and E when the power supply has an internal resistor or C and E to use the internal resistor of this device. You must not connect C and D at the same time!
- 6 Terminals for relay 1
- 7 Terminals for relay 2

The device is equipped with an internal HART[®] access for the NonEx-version (A2 and B2) that offers the opportunity to access the field device via HART[®] handheld or HART[®] modem.

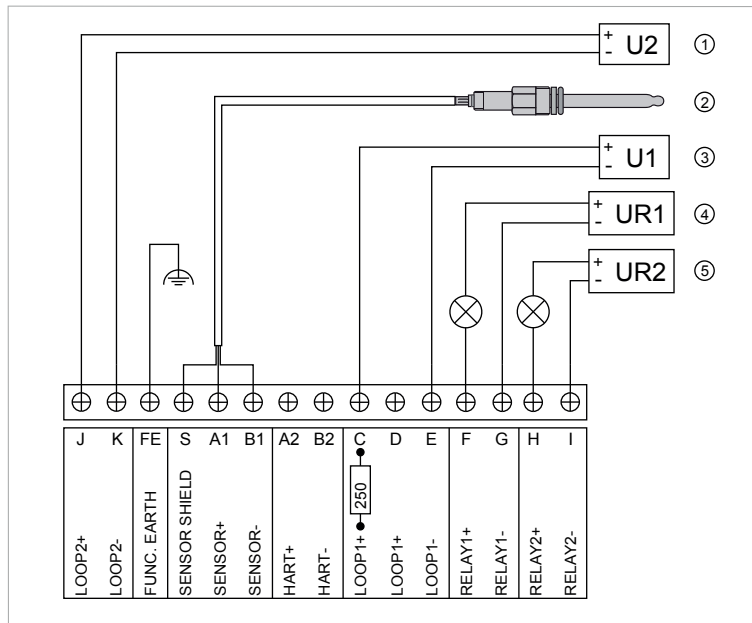

Figure 4-2: Connection example with a 2-wire field device

- 1 Power supply for loop 2. Used for second 4...20 mA output and/or NE107 LEDs and backlight.
- 2 Connected field device, e.g. SMARTPAT PH.
- 3 Power supply for loop 1. Main loop for operating the device, in this case with usage of internal resistor.
- 4 Power supply for relay 1
- 5 Power supply for relay 2

4.2 Connecting the field device cable

When connecting the power supply, always note the safety regulations of the current state of the art. To avoid fatal injuries, destruction or damage of the device or measuring errors, also note the following items:

- Cables may only be connected when the power is switched off.
- Always keep the housing of the device well closed if you do not perform any installation works. The function of the housing is to protect the electronic equipment from dust and moisture.
- Check the nameplate and assure that the power supply meets the voltage of the device. The device is loop powered and operates in the range of 20...30 VDC with a voltage drop < 4 V. If the power supply is below 20 VDC the device and field device will not work. If the power supply is above 30 VDC the device and field device sensor may be damaged/destroyed.

Do not use the integrated 250 Ohm HART[®] resistor of the device, when using an Ex isolation amplifier of third-party with integrated 250 Ohm HART[®] resistor.

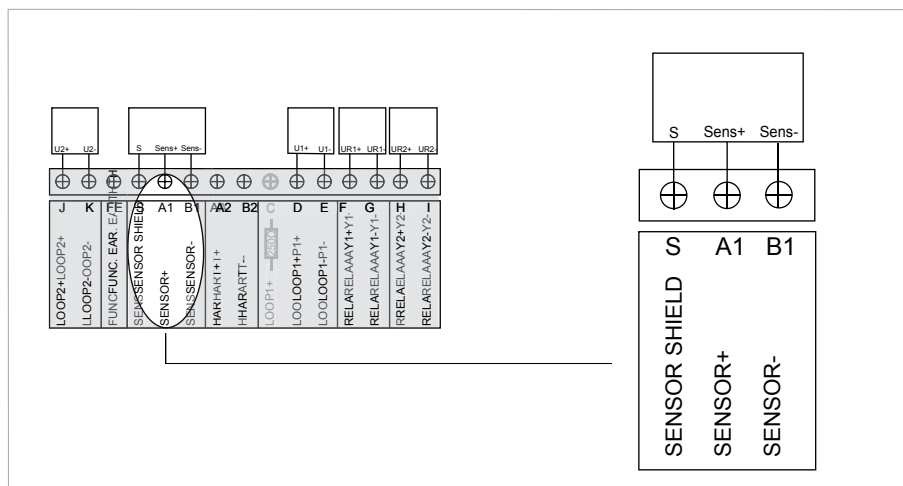

Figure 4-3: Connecting the field device cable

The cable glands installed by the manufacturer are designed for a cable diameter of 3...6,5 mm for M12 and 5...10 mm for M16. If you are using cables with a larger diameter than 3...6,5 mm for M12 and 5...10 mm for M16, you must replace the manufacturer's cable glands with suitable ones. The operator is responsible for the correct sealing of cable glands.

4.3 Connecting the second current output

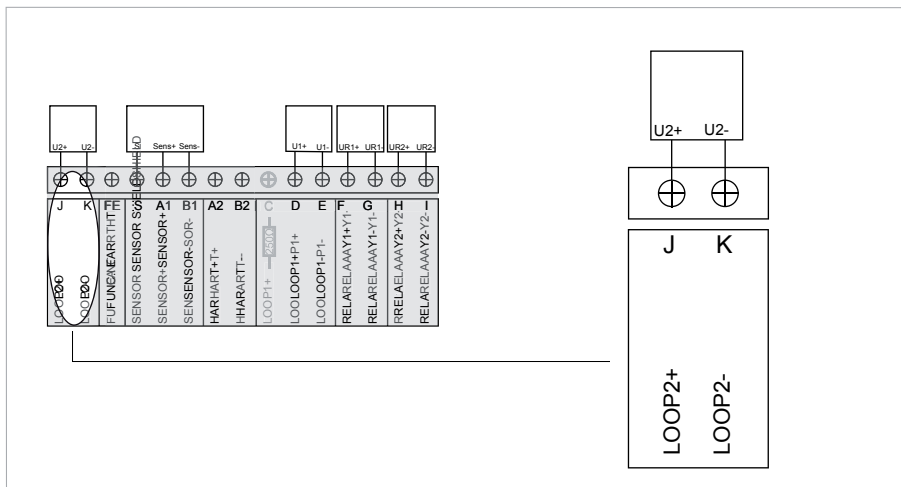

Figure 4-4: Connection of second current output

The second current output can be either used as current output for any HART® variable or as power supply for backlight and LEDs for NAMUR NE 107 signalisation if supported by field device (field device must support extended command 523: Read Condensed Status Mapping Array).

4.4 Connecting the relay outputs

The device has two solid state relays that can work as status output, system alarm, cleaning control or limit switch:

- The relay contacts are electrically isolated from each other and from all other circuits.
- The output stages of the status outputs / limit switches behave like relay contacts.
- Possible conditions: NO (normally open) or NC (normally closed).

Connection values:

- Maximum Voltage = 30 V
- Maximum Load Current = 75 mA up to 55°C and 50 mA above 55°C
- Max On resistance = 10 Ohm

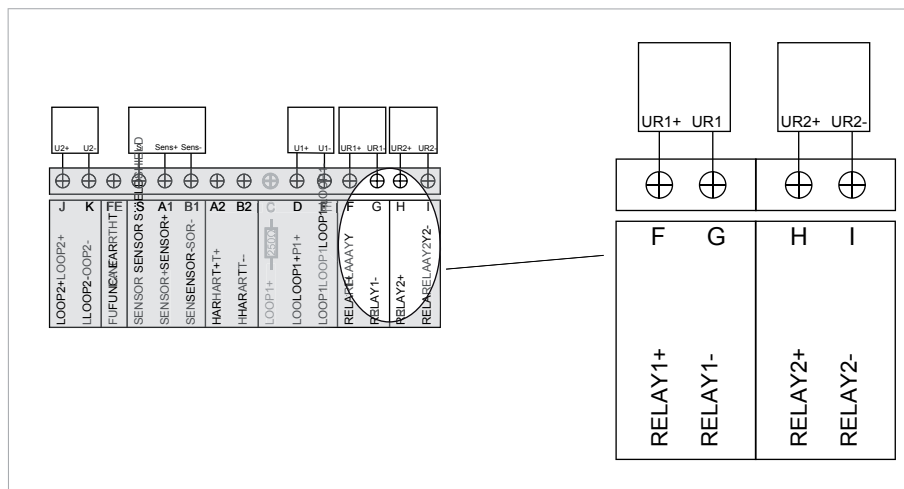

Figure 4-5: Connecting the relay outputs

4.5 Connecting the external HART adapter

The external HART[®] adapter is an optional feature that offers the opportunity to access the field device without opening the housing.

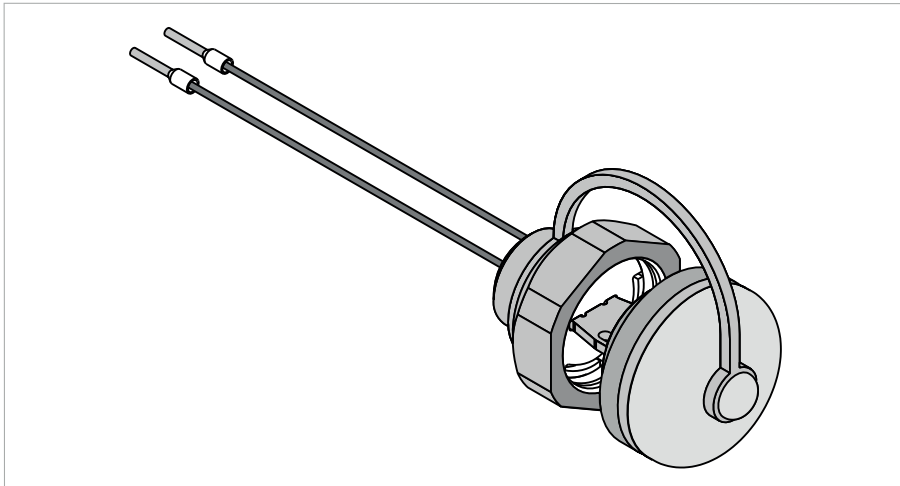

Figure 4-6: External HART adapter

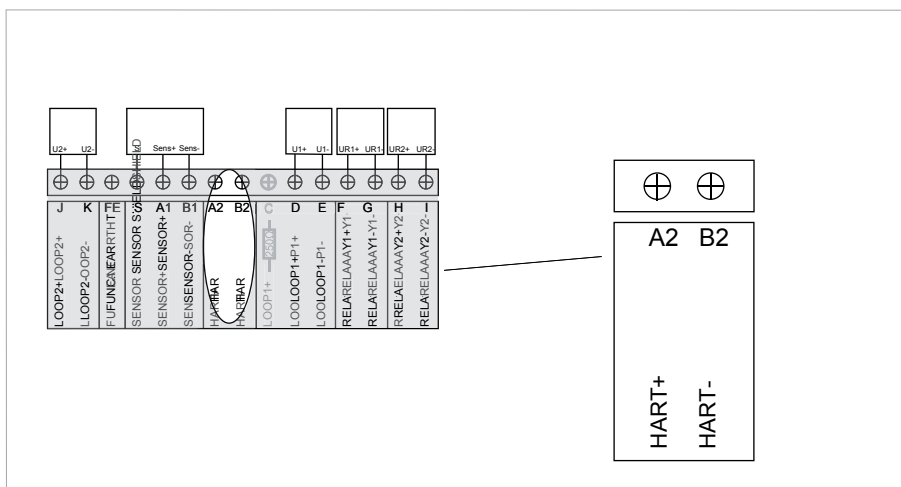

Figure 4-7: Connection of the external HART[®] adapter

- 1 Open the housing.
- 2 Remove the middle M16 cable gland and screw the HART[®] adapter.
- 3 Connect the HART[®] adapter to connections A2 and B2.

Consider that the cap needs to be closed for a protection of the electronics parts.

4.6 Power supply

To avoid fatal injuries as well as destruction or damage of the device assure a correct installation before switching on the power. This includes:

- The device is mechanically safe, mounting and power connection comply with the regulations.
- The electrical terminal compartments must be secured, i.e. the housing has to be closed and the screws have to be tightened.
- The electrical operating data of the power supply comply with the requirements of the device.

Observe without fail the local occupational health and safety regulations.

Any work done on the electrical components of the measuring device may only be carried out by properly trained specialists.

When connecting the power supply, always note the safety regulations of the current state of the art. To avoid fatal injuries, destruction or damage of the device or measuring errors, also note the following items:

- Cables may only be connected when the power is switched off.
- Always keep the housing of the device well closed if you do not perform any installation works. The function of the housing is to protect the electronic equipment from dust and moisture.
- Check the nameplate and assure that the power supply meets the voltage of the device. The device is loop powered and operates in the range of 20...30 VDC with a voltage drop < 4 V. If the power supply is below 20 VDC the device and field device will not work. If the power supply is above 30 VDC the device and field device sensor may be damaged/destroyed.

Do not use the integrated 250 Ohm HART[®] resistor of the device, when using an Ex isolation amplifier of third-party with integrated 250 Ohm HART[®] resistor.

The device and the field device require a minimum operating voltage of 20 VDC. The power supply is provided via the 2-wire interface (4...20 mA).

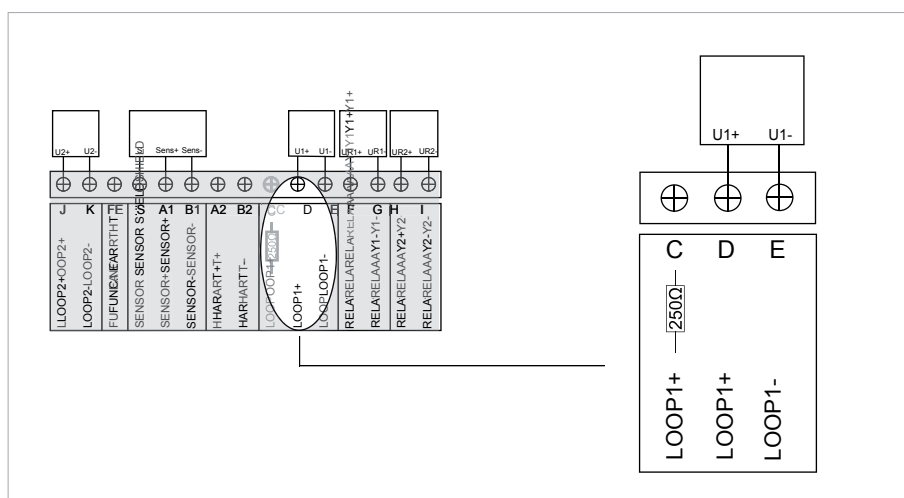

Figure 4-8: Connection of the power supply

4.7 Connecting the SHD 200 for use in an active 4...20 mA current output

To avoid fatal injuries as well as destruction or damage of the device assure a correct installation before switching on the power. This includes:

- *The device is mechanically safe, mounting and power connection comply with the regulations.*
- *The electrical terminal compartments must be secured, i.e. the housing has to be closed and the screws have to be tightened.*
- *The electrical operating data of the power supply comply with the requirements of the device.*

Observe without fail the local occupational health and safety regulations.

Any work done on the electrical components of the measuring device may only be carried out by properly trained specialists.

When connecting the power supply, always note the safety regulations of the current state of the art. To avoid fatal injuries, destruction or damage of the device or measuring errors, also note the following items:

- *Cables may only be connected when the power is switched off.*
- *Always keep the housing of the device well closed if you do not perform any installation works. The function of the housing is to protect the electronic equipment from dust and moisture.*
- *Check the nameplate and assure that the power supply meets the voltage of the device. The device is loop powered and operates in the range of 20...30 VDC with a voltage drop < 4 V. If the power supply is below 20 VDC the device and field device will not work. If the power supply is above 30 VDC the device and field device may be damaged/destroyed.*

Do not use the integrated 250 Ohm HART[®] resistor of the device, when using an Ex isolation amplifier of third-party with integrated 250 Ohm HART[®] resistor.

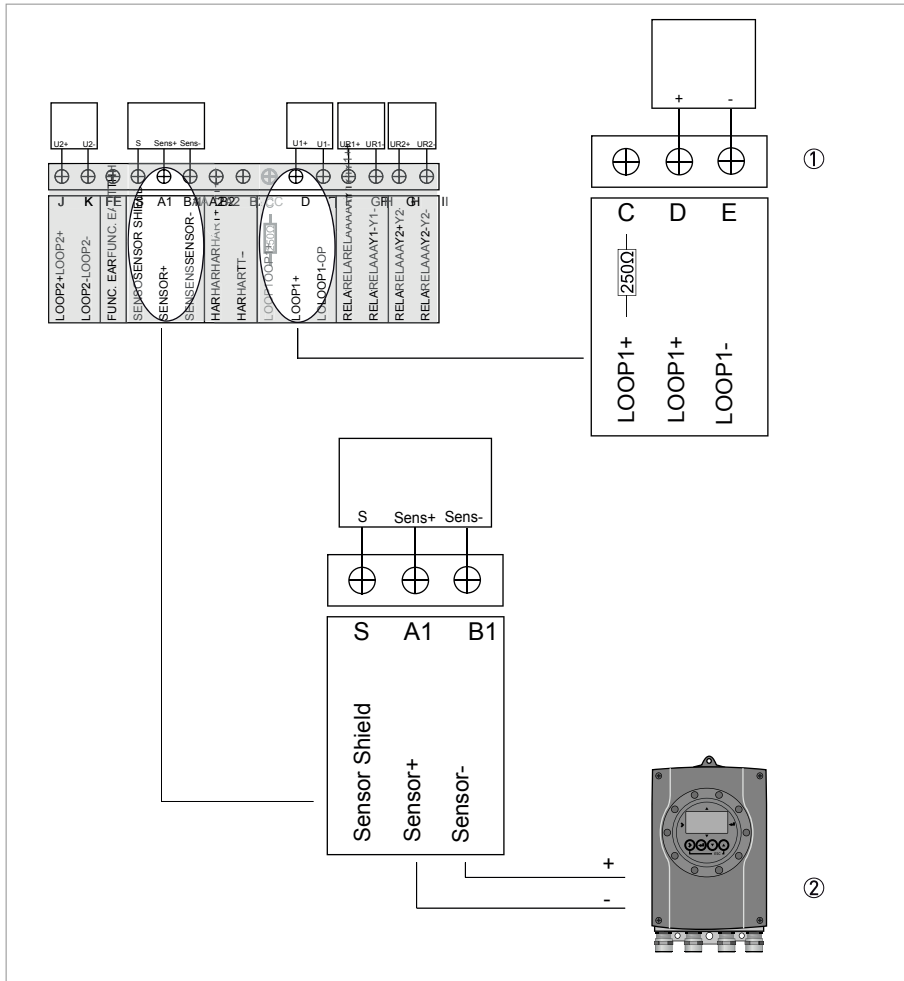

Figure 4-9: Connection for use in an active 4...20 mA current output

- 1 Connection to process control system (passive input)
- 2 Active current output of field device

Connect output + from field device to SENSOR - and output - from field device to SENSOR +.

For information on connecting the second current output refer to *Connecting the second current output* on page 17 , connecting the relays refer to *Connecting the relay outputs* on page 18 and connecting the external HART adapter refer to *Connecting the external HART adapter* on page 19.

Алматы (7273)495-231
Ангарск (3955)60-70-56
Архангельск (8182)63-90-72
Астрахань (8512)99-46-04
Барнаул (3852)73-04-60
Белгород (4722)40-23-64
Благовещенск (4162)22-76-07
Брянск (4832)59-03-52
Владивосток (423)249-28-31
Владикавказ (8672)28-90-48
Владимир (4922)49-43-18
Волгоград (844)278-03-48
Вологда (8172)26-41-59
Воронеж (473)204-51-73
Екатеринбург (343)384-55-89
Иваново (4932)77-34-06
Ижевск (3412)26-03-58
Иркутск (395)279-98-46
Казань (843)206-01-48

Калининград (4012)72-03-81
Калуга (4842)92-23-67
Кемерово (3842)65-04-62
Киров (8332)68-02-04
Коломна (4966)23-41-49
Кострома (4942)77-07-48
Краснодар (861)203-40-90
Красноярск (391)204-63-61
Курган (3522)50-90-47
Курск (4712)77-13-04
Липецк (4742)52-20-81
Магнитогорск (3519)55-03-13
Москва (495)268-04-70
Мурманск (8152)59-64-93
Набережные Челны (8552)20-53-41
Нижний Новгород (831)429-08-12
Новокузнецк (3843)20-46-81
Новосибирск (383)227-86-73
Ноябрьск (3496)41-32-12

Омск (3812)21-46-40
Орел (4862)44-53-42
Оренбург (3532)37-68-04
Пенза (8412)22-31-16
Пермь (342)205-81-47
Петрозаводск (8142)55-98-37
Псков (8112)59-10-37
Ростов-на-Дону (863)308-18-15
Рязань (4912)46-61-64
Самара (846)206-03-16
Санкт-Петербург (812)309-46-40
Саранск (8342)22-96-24
Саратов (845)249-38-78
Севастополь (8692)22-31-93
Симферополь (3652)67-13-56
Смоленск (4812)29-41-54
Сочи (862)225-72-31
Ставрополь (8652)20-65-13
Сургут (3462)77-98-35

Сыктывкар (8212)25-95-17
Тамбов (4752)50-40-97
Тверь (4822)63-31-35
Тольятти (8482)63-91-07
Томск (3822)98-41-53
Тула (4872)33-79-87
Тюмень (3452)66-21-18
Улан-Удэ (3012)59-97-51
Ульяновск (8422)24-23-59
Уфа (347)229-48-12
Хабаровск (4212)92-98-04
Чебоксары (8352)28-53-07
Челябинск (351)202-03-61
Череповец (8202)49-02-64
Чита (3022)38-34-83
Якутск (4112)23-90-97
Ярославль (4852)69-52-93

Россия +7(495)268-04-70

Казахстан +7(7172)727-132

Киргизия +996(312)96-26-47

<https://opti.nt-rt.ru> || opti@nt-rt.ru