

Алматы (7273)495-231
Ангарск (3955)60-70-56
Архангельск (8182)63-90-72
Астрахань (8512)99-46-04
Барнаул (3852)73-04-60
Белгород (4722)40-23-64
Благовещенск (4162)22-76-07
Брянск (4832)59-03-52
Владивосток (423)249-28-31
Владикавказ (8672)28-90-48
Владимир (4922)49-43-18
Волгоград (844)278-03-48
Вологда (8172)26-41-59
Воронеж (473)204-51-73
Екатеринбург (343)384-55-89
Иваново (4932)77-34-06
Ижевск (3412)26-03-58
Иркутск (395)279-98-46
Казань (843)206-01-48

Калининград (4012)72-03-81
Калуга (4842)92-23-67
Кемерово (3842)65-04-62
Киров (8332)68-02-04
Коломна (4966)23-41-49
Кострома (4942)77-07-48
Краснодар (861)203-40-90
Красноярск (391)204-63-61
Курган (3522)50-90-47
Курск (4712)77-13-04
Липецк (4742)52-20-81
Магнитогорск (3519)55-03-13
Москва (495)268-04-70
Мурманск (8152)59-64-93
Набережные Челны (8552)20-53-41
Нижний Новгород (831)429-08-12
Новокузнецк (3843)20-46-81
Новосибирск (383)227-86-73
Ноябрьск (3496)41-32-12

Омск (3812)21-46-40
Орел (4862)44-53-42
Оренбург (3532)37-68-04
Пенза (8412)22-31-16
Пермь (342)205-81-47
Петрозаводск (8142)55-98-37
Псков (8112)59-10-37
Ростов-на-Дону (863)308-18-15
Рязань (4912)46-61-64
Самара (846)206-03-16
Санкт-Петербург (812)309-46-40
Саранск (8342)22-96-24
Саратов (845)249-38-78
Севастополь (8692)22-31-93
Симферополь (3652)67-13-56
Смоленск (4812)29-41-54
Сочи (862)225-72-31
Ставрополь (8652)20-65-13
Сургут (3462)77-98-35

Сыктывкар (8212)25-95-17
Тамбов (4752)50-40-97
Тверь (4822)63-31-35
Тольятти (8482)63-91-07
Томск (3822)98-41-53
Тула (4872)33-79-87
Тюмень (3452)66-21-18
Улан-Удэ (3012)59-97-51
Ульяновск (8422)24-23-59
Уфа (347)229-48-12
Хабаровск (4212)92-98-04
Чебоксары (8352)28-53-07
Челябинск (351)202-03-61
Череповец (8202)49-02-64
Чита (3022)38-34-83
Якутск (4112)23-90-97
Ярославль (4852)69-52-93

Россия +7(495)268-04-70

Казахстан +7(7172)727-132

Киргизия +996(312)96-26-47

<https://opti.nt-rt.ru> || opti@nt-rt.ru

УРОВНЕМЕРЫ OPTIWAVE 8300 C Marine



Dimensions and weight (DN125 standard flange)

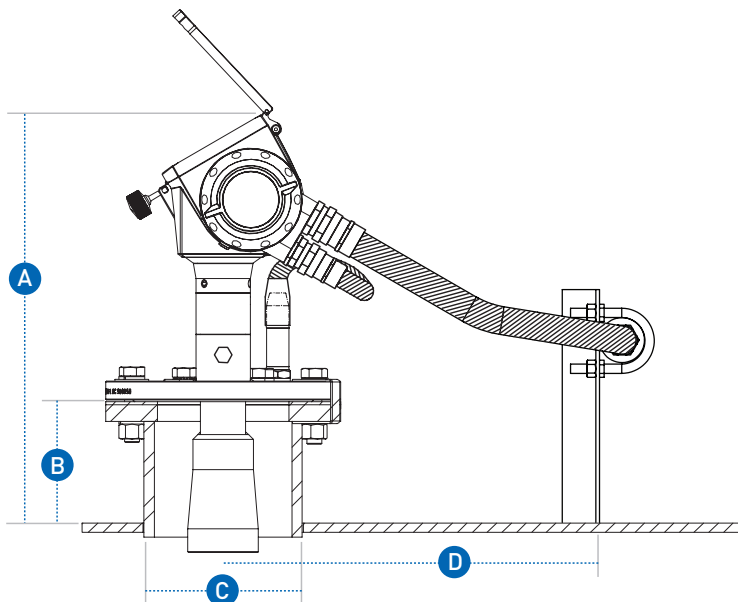

Dimensions (mm)				Weight (kg)	Dimensions (inches)				Weight (lbs)
A	B	C	D		A	B	C	D	
433	141	ø 170	400	20	17	5.6	ø 6.7	16	44

Easy installation and light weight

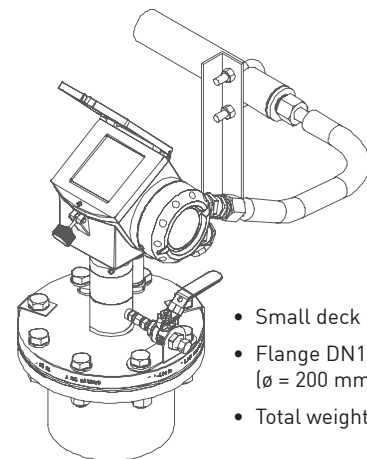

- Small deck socket
- Flange DN125 (ø = 200 mm)
- Total weight: 20 kg

Non contact measurements

The OPTIWAVE 8300 C Marine offers completely non contact level measurements in cargo tanks.

The transmitter is located in the radar head, transmitting through the pressure sealing part.

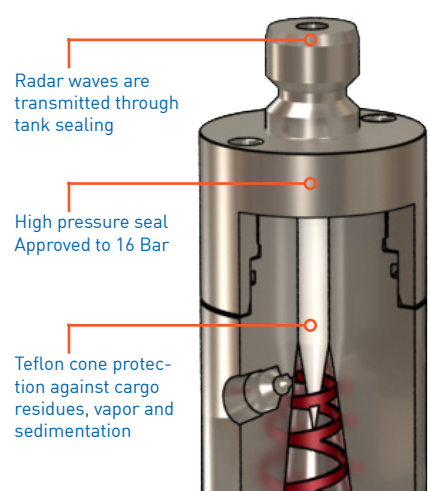

Radar antennas

Horn antenna:

Standard antenna for most tanker applications.

Drop antenna:

As an alternative to horn antenna we can also offer a solid drop antenna solution. The construction of the drop antenna makes it ideal for sticky/contaminating liquids or dust-laden atmospheres where product build-up inside a horn antenna is likely to occur.



OPTIWAVE 8300 C
Horn antenna

OPTIWAVE 8300 C
Drop antenna

Measuring system	
Measuring principle	Frequency Modulated Continuous Wave (FMCW), 24 GHz
Application range	Level measurement of liquids, pastes, slurries and solids
Measuring range	0...40 m / 0-132 ft
Beam angle	± 5°
Measuring accuracy	
Accuracy (at reference conditions)	up to 20 m / 66 ft < 2 mm / 0.08" 20...40 m / 66...132 ft m ± 0.01% of distance
Repeatability	≤ 0.5 x error of measurement
Measured value resolution	0.1 mm / 0.04"
Ambient conditions	
Hazardous locations	Intrinsically safe, zone 0, 1, 2 Temperature classes: T6...T1 Explosion groups: IIA...IIC
Ambient temperature	-40...+70 °C / -40...+160 °F (signal converter)
Flange temperature	-40...+200 °C / -40...+390 °F optional -60...+250 °C / -75...+480 °F
Ingress protection	IP 66/67 (signal converter)
Product conditions	
Physical properties	No effect on measurement results
Dielectric constant (ϵ_r)	≤ 1.5
Product limitations	Liquid ammonia (NH ₃), Liquid hydrogen (H ₂), Liquid helium (He)
Process temperature	Unrestricted (but beware ambient and flange temperatures)
Materials	
Signal converter	Stainless steel 316L
Flange system / antenna	Stainless steel 316L (1.4404) (standard) or 3% Molybden Mo
Gaskets	FPM (Viton), Karlez 6375 (others optional)
Process connection	DIN 2501 DN 125 / PN 16 (standard)
Power supply and output	
Powered by	4-20 mA
Protocols	HART®
Current output	4-20 mA passive
Certificates and approvals	
Ex approvals	Intrinsically safe according to ATEX and IEC
IACS approvals	DNV, ABS, GL, LR, BV, CCS, NK, RINA, KR

Standard installation

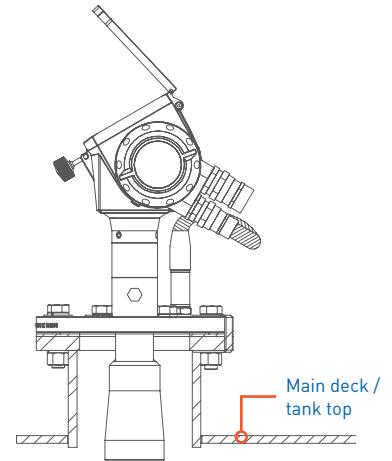

Stillwell installation

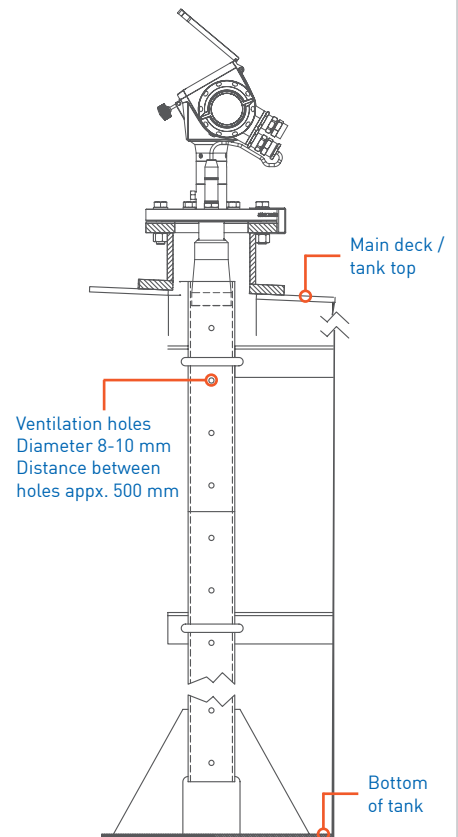

Redundant level indication



The OPTIWAVE Cargo Level Radar is a highly accurate and reliable instrument for measuring the ullage/level. With its heavy duty stainless steel housing, it is designed to withstand the roughest conditions on deck.

Well protected by a stainless steel cover, it carries a backup display for redundant indication. Loading may continue with a man on deck, if level information is lost on the main monitoring station.

Closed cleaning of radar antenna

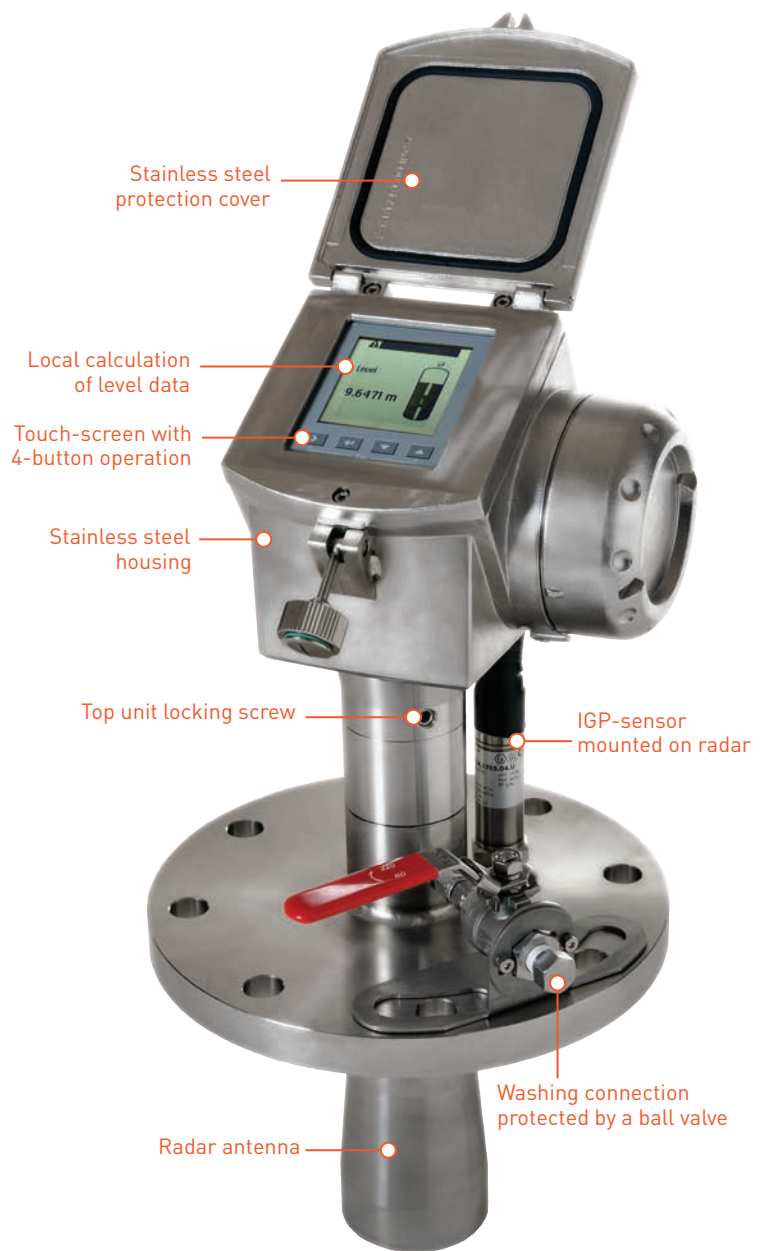

Closed service



Алматы (7273)495-231
Ангарск (3955)60-70-56
Архангельск (8182)63-90-72
Астрахань (8512)99-46-04
Барнаул (3852)73-04-60
Белгород (4722)40-23-64
Благовещенск (4162)22-76-07
Брянск (4832)59-03-52
Владивосток (423)249-28-31
Владикавказ (8672)28-90-48
Владимир (4922)49-43-18
Волгоград (844)278-03-48
Вологда (8172)26-41-59
Воронеж (473)204-51-73
Екатеринбург (343)384-55-89
Иваново (4932)77-34-06
Ижевск (3412)26-03-58
Иркутск (395)279-98-46
Казань (843)206-01-48

Калининград (4012)72-03-81
Калуга (4842)92-23-67
Кемерово (3842)65-04-62
Киров (8332)68-02-04
Коломна (4966)23-41-49
Кострома (4942)77-07-48
Краснодар (861)203-40-90
Красноярск (391)204-63-61
Курган (3522)50-90-47
Курск (4712)77-13-04
Липецк (4742)52-20-81
Магнитогорск (3519)55-03-13
Москва (495)268-04-70
Мурманск (8152)59-64-93
Набережные Челны (8552)20-53-41
Нижний Новгород (831)429-08-12
Новокузнецк (3843)20-46-81
Новосибирск (383)227-86-73
Ноябрьск(3496)41-32-12

Омск (3812)21-46-40
Орел (4862)44-53-42
Оренбург (3532)37-68-04
Пенза (8412)22-31-16
Пермь (342)205-81-47
Петрозаводск (8142)55-98-37
Псков (8112)59-10-37
Ростов-на-Дону (863)308-18-15
Рязань (4912)46-61-64
Самара (846)206-03-16
Санкт-Петербург (812)309-46-40
Саранск (8342)22-96-24
Саратов (845)249-38-78
Севастополь (8692)22-31-93
Симферополь (3652)67-13-56
Смоленск (4812)29-41-54
Сочи (862)225-72-31
Ставрополь (8652)20-65-13
Сургут (3462)77-98-35

Сыктывкар (8212)25-95-17
Тамбов (4752)50-40-97
Тверь (4822)63-31-35
Тольятти (8482)63-91-07
Томск (3822)98-41-53
Тула (4872)33-79-87
Тюмень (3452)66-21-18
Улан-Удэ (3012)59-97-51
Ульяновск (8422)24-23-59
Уфа (347)229-48-12
Хабаровск (4212)92-98-04
Чебоксары (8352)28-53-07
Челябинск (351)202-03-61
Череповец (8202)49-02-64
Чита (3022)38-34-83
Якутск (4112)23-90-97
Ярославль (4852)69-52-93

Россия +7(495)268-04-70

Казахстан +7(7172)727-132

Киргизия +996(312)96-26-47

<https://opti.nt-rt.ru> || opti@nt-rt.ru