

Алматы (7273)495-231  
Ангарск (3955)60-70-56  
Архангельск (8182)63-90-72  
Астрахань (8512)99-46-04  
Барнаул (3852)73-04-60  
Белгород (4722)40-23-64  
Благовещенск (4162)22-76-07  
Брянск (4832)59-03-52  
Владивосток (423)249-28-31  
Владикавказ (8672)28-90-48  
Владимир (4922)49-43-18  
Волгоград (844)278-03-48  
Вологда (8172)26-41-59  
Воронеж (473)204-51-73  
Екатеринбург (343)384-55-89  
Иваново (4932)77-34-06  
Ижевск (3412)26-03-58  
Иркутск (395)279-98-46  
Казань (843)206-01-48

Калининград (4012)72-03-81  
Калуга (4842)92-23-67  
Кемерово (3842)65-04-62  
Киров (8332)68-02-04  
Коломна (4966)23-41-49  
Кострома (4942)77-07-48  
Краснодар (861)203-40-90  
Красноярск (391)204-63-61  
Курган (3522)50-90-47  
Курск (4712)77-13-04  
Липецк (4742)52-20-81  
Магнитогорск (3519)55-03-13  
Москва (495)268-04-70  
Мурманск (8152)59-64-93  
Набережные Челны (8552)20-53-41  
Нижний Новгород (831)429-08-12  
Новокузнецк (3843)20-46-81  
Новосибирск (383)227-86-73  
Ноябрьск (3496)41-32-12

Омск (3812)21-46-40  
Орел (4862)44-53-42  
Оренбург (3532)37-68-04  
Пенза (8412)22-31-16  
Пермь (342)205-81-47  
Петрозаводск (8142)55-98-37  
Псков (8112)59-10-37  
Ростов-на-Дону (863)308-18-15  
Рязань (4912)46-61-64  
Самара (846)206-03-16  
Санкт-Петербург (812)309-46-40  
Саранск (8342)22-96-24  
Саратов (845)249-38-78  
Севастополь (8692)22-31-93  
Симферополь (3652)67-13-56  
Смоленск (4812)29-41-54  
Сочи (862)225-72-31  
Ставрополь (8652)20-65-13  
Сургут (3462)77-98-35

Сыктывкар (8212)25-95-17  
Тамбов (4752)50-40-97  
Тверь (4822)63-31-35  
Тольятти (8482)63-91-07  
Томск (3822)98-41-53  
Тула (4872)33-79-87  
Тюмень (3452)66-21-18  
Улан-Удэ (3012)59-97-51  
Ульяновск (8422)24-23-59  
Уфа (347)229-48-12  
Хабаровск (4212)92-98-04  
Чебоксары (8352)28-53-07  
Челябинск (351)202-03-61  
Череповец (8202)49-02-64  
Чита (3022)38-34-83  
Якутск (4112)23-90-97  
Ярославль (4852)69-52-93

Россия +7(495)268-04-70

Казахстан +7(7172)727-132

Киргизия +996(312)96-26-47

<https://opti.nt-rt.ru> || [opti@nt-rt.ru](mailto:opti@nt-rt.ru)

## УРОВНЕМЕРЫ

### OPTIWAVE-M 7400 C

### OPTIWAVE-M 7500 C



OPTIWAVE-M 7400 C 24 GHz



OPTIWAVE-M 7500 C 80 GHz

## Dimensions and weight (DN125 standard flange) 24 GHz

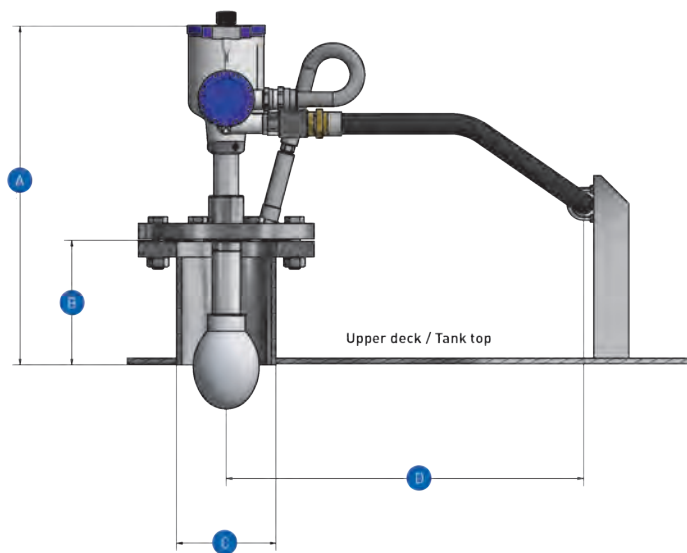

Dimensions (mm)				Weight (kg)	Dimensions (inches)				Weight (lbs)
A	B	C	D		A	B	C	D	
307	141	∅ 168	400	20	12	5.6	∅ 6.6	15.8	44

## Radar antennas

**Horn antenna:**  
Suitable for small/medium tankers with closed cleaning



**Drop antenna:**  
The construction of the drop antenna makes it ideal for sticky/contaminating liquids or dust-laden atmospheres where product build-up inside a horn antenna is likely to occur.



**Lens antenna:**  
Narrow beam. Suitable for large oil and product tankers.



## Ultra narrow beam installation (DN 150) 80 GHz for narrow tanks

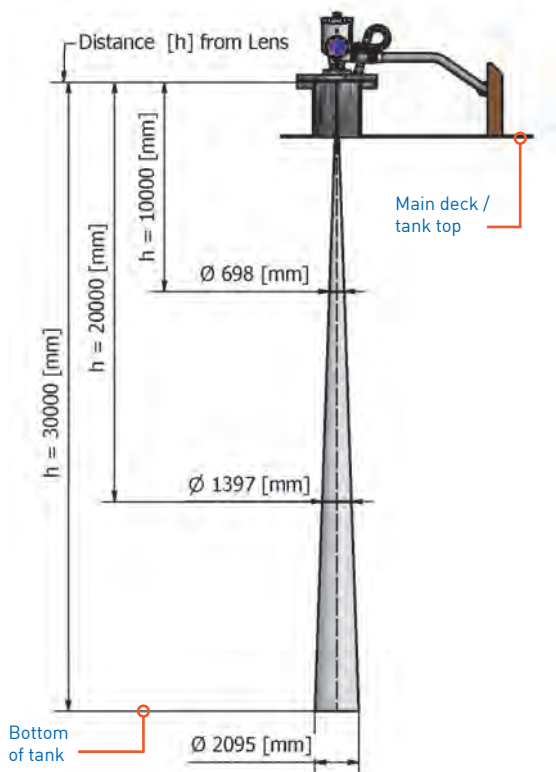

### Footprint at different levels (height from lens to liquid surface) (mm)

#### OPTIWAVE-M 7500 C Lens Antenna d 40mm Peek Beam angle $\pm 4^\circ$

Tank height (h)	5 000	10 000	20 000	25 000	30 000
Diameter footprint $\emptyset$	699	1399	2797	3496	4196

#### OPTIWAVE-M 7500 C Lens Antenna d 70mm Peek Beam angle $\pm 2^\circ$

Tank height (h)	5 000	10 000	20 000	25 000	30 000
Diameter footprint $\emptyset$	349	698	1397	1746	2095

### Footprint at different levels (height from lens to liquid surface) (inch)

#### OPTIWAVE-M 7500 C Lens Antenna d 40mm Peek Beam angle $\pm 4^\circ$

Tank height (h)	197	394	787	984	1181
Diameter footprint $\emptyset$	28	55	110	138	165

#### OPTIWAVE-M 7500 C Lens Antenna d 70mm Peek Beam angle $\pm 2^\circ$

Tank height (h)	197	394	787	984	1181
Diameter footprint $\emptyset$	14	27	55	69	82

The OPTIWAVE-M 7500 C 80 GHz radar keeps operating under the most difficult conditions in the tank and on the deck. The beam of  $\pm 2^\circ$  makes it easy to install even on narrow tanks.

The OPTIWAVE-M 7500 C 80 GHz radar is the ideal choice for measuring ullage on tankers and marine applications, from the smallest up to the largest tanks.

Measuring system	OPTIWAVE-M 7400 C 24 GHz	OPTIWAVE-M 7500 C 80 GHz
Measuring principle	Frequency Modulated Continuous Wave (FMCW), 24 GHz	Frequency Modulated Continuous Wave (FMCW), 80 GHz
Application range	Level measurement of liquids, pastes, slurries and solids	Level measurement of liquids, pastes, slurries and solids
Measuring range	0...40 m / 0-132 ft	0...40 m / 0-132 ft
Beam angle	± 4°	± 2° / ± 4°
<b>Measuring accuracy</b>		
Accuracy (at reference conditions)	up to 20 m / 66 ft < 2 mm / 0.08" 20...40 m / 66...132 ft ± 0.01% of distance	up to 20 m / 66 ft < 2 mm / 0.08" 20...40 m / 66...132 ft ± 0.01% of distance
Repeatability	≤ 0.5 x error of measurement	≤ 0.5 x error of measurement
Measured value resolution	0.1 mm / 0.04"	0.1 mm / 0.04"
<b>Ambient conditions</b>		
Hazardous locations	Intrinsically safe, zone 0, 1, 2 Temperature classes: T6...T3 Explosion groups: IIA...IIC	Intrinsically safe, zone 0, 1, 2 Temperature classes: T6...T3 Explosion groups: IIA...IIC
Ambient temperature	-40...+70°C / -40...+160°F (signal converter)	-40...+70°C / -40...+160°F (signal converter)
Flange temperature	-40...+200°C / -40...+390°F optional -60...+250°C / -75...+480°F	-40...+200°C / -40...+390°F optional -60...+250°C / -75...+480°F
Ingress protection	IP 66 and IP 67 (signal converter)	IP 66 and IP 67 (signal converter)
<b>Product conditions</b>		
Dielectric constant (ε <sub>r</sub> )	Down to 1.5	Down to 1.5
Product limitations	Liquid ammonia (NH <sub>3</sub> ), Liquid hydrogen (H <sub>2</sub> ), Liquid helium (He), LNG (due to CT requirements)	Liquid ammonia (NH <sub>3</sub> ), Liquid hydrogen (H <sub>2</sub> ), Liquid helium (He), LNG (due to CT requirements)
Process temperature	Unrestricted (but observe ambient and flange temperatures)	Unrestricted (but observe ambient and flange temperatures)
<b>Materials</b>		
Signal converter	Stainless steel 316L	Stainless steel 316L
Flange system	Stainless steel 316L (1.4404) (standard) or higher Molybden (Mo) on request	Stainless steel 316L (1.4404) (standard) or higher Molybden (Mo) on request
Horn Antenna	Stainless steel 316L (1.4404) (standard) or higher Molybden (Mo) on request	N/A
Bulb Antenna	PP or PTFE	N/A
Lens Antenna	N/A	Peek
Gaskets	FPM (Viton), Kalrez 6375 (others optional)	FPM (Viton), Kalrez 6375 (others optional)
Process connection	DIN 2501 DN 125 / PN 16 (standard)	DIN 2501 DN 125 / PN 16 (standard)
<b>Power supply and output</b>		
Powered by	4-20 mA (Loop power, 2 wired)	4-20 mA (Loop power, 2 wired)
Protocols	HART®	HART®
Current output	4-20 mA passive	4-20 mA passive
<b>Certificates and approvals</b>		
Ex approvals	Intrinsically safe according to ATEX and IEC	Intrinsically safe according to ATEX and IEC
IACS approvals	DNV, ABS, GL, LR, BV, CCS, NK, RINA, KR	DNV, ABS, GL, LR, BV, CCS, NK, RINA, KR

## Redundant level indication

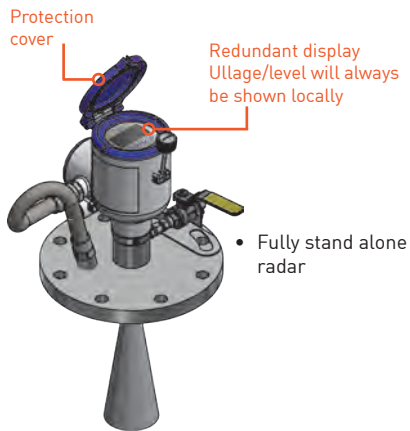

The OPTIWAVE Cargo Level Radars are highly accurate and reliable instruments for measuring the ullage/level. With heavy duty stainless steel housing, they are designed to withstand the roughest conditions on deck.

Well protected by a stainless steel cover, they carry a backup display for redundant indication. Cargo operations may continue with a man on deck, if level information is lost on the main monitoring station.

## Closed cleaning of lens/horn antenna

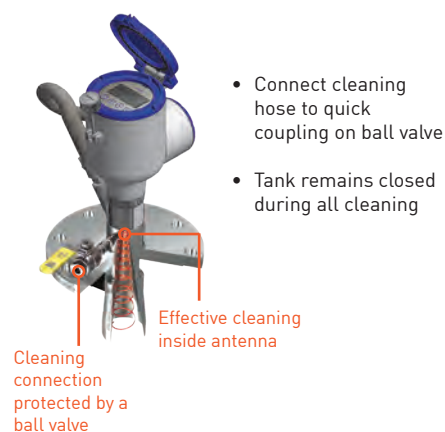

## Replacement of OPTIWAVE-M 7400 C

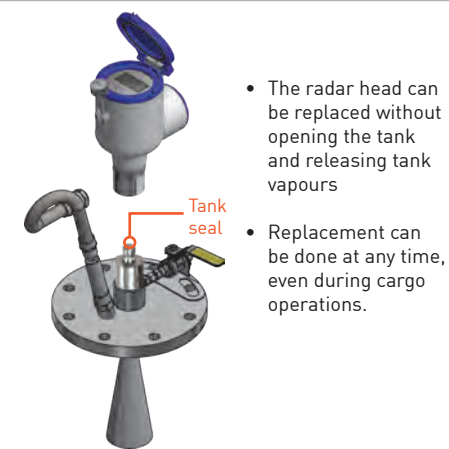

Алматы (7273)495-231  
Ангарск (3955)60-70-56  
Архангельск (8182)63-90-72  
Астрахань (8512)99-46-04  
Барнаул (3852)73-04-60  
Белгород (4722)40-23-64  
Благовещенск (4162)22-76-07  
Брянск (4832)59-03-52  
Владивосток (423)249-28-31  
Владикавказ (8672)28-90-48  
Владимир (4922)49-43-18  
Волгоград (844)278-03-48  
Вологда (8172)26-41-59  
Воронеж (473)204-51-73  
Екатеринбург (343)384-55-89  
Иваново (4932)77-34-06  
Ижевск (3412)26-03-58  
Иркутск (395)279-98-46  
Казань (843)206-01-48

Калининград (4012)72-03-81  
Калуга (4842)92-23-67  
Кемерово (3842)65-04-62  
Киров (8332)68-02-04  
Коломна (4966)23-41-49  
Кострома (4942)77-07-48  
Краснодар (861)203-40-90  
Красноярск (391)204-63-61  
Курган (3522)50-90-47  
Курск (4712)77-13-04  
Липецк (4742)52-20-81  
Магнитогорск (3519)55-03-13  
Москва (495)268-04-70  
Мурманск (8152)59-64-93  
Набережные Челны (8552)20-53-41  
Нижний Новгород (831)429-08-12  
Новокузнецк (3843)20-46-81  
Новосибирск (383)227-86-73  
Ноябрьск (3496)41-32-12

Омск (3812)21-46-40  
Орел (4862)44-53-42  
Оренбург (3532)37-68-04  
Пенза (8412)22-31-16  
Пермь (342)205-81-47  
Петрозаводск (8142)55-98-37  
Псков (8112)59-10-37  
Ростов-на-Дону (863)308-18-15  
Рязань (4912)46-61-64  
Самара (846)206-03-16  
Санкт-Петербург (812)309-46-40  
Саранск (8342)22-96-24  
Саратов (845)249-38-78  
Севастополь (8692)22-31-93  
Симферополь (3652)67-13-56  
Смоленск (4812)29-41-54  
Сочи (862)225-72-31  
Ставрополь (8652)20-65-13  
Сургут (3462)77-98-35

Сыктывкар (8212)25-95-17  
Тамбов (4752)50-40-97  
Тверь (4822)63-31-35  
Тольятти (8482)63-91-07  
Томск (3822)98-41-53  
Тула (4872)33-79-87  
Тюмень (3452)66-21-18  
Улан-Удэ (3012)59-97-51  
Ульяновск (8422)24-23-59  
Уфа (347)229-48-12  
Хабаровск (4212)92-98-04  
Чебоксары (8352)28-53-07  
Челябинск (351)202-03-61  
Череповец (8202)49-02-64  
Чита (3022)38-34-83  
Якутск (4112)23-90-97  
Ярославль (4852)69-52-93

Россия +7(495)268-04-70

Казахстан +7(7172)727-132

Киргизия +996(312)96-26-47

<https://opti.nt-rt.ru> || [opti@nt-rt.ru](mailto:opti@nt-rt.ru)