

Алматы (7273)495-231  
Ангарск (3955)60-70-56  
Архангельск (8182)63-90-72  
Астрахань (8512)99-46-04  
Барнаул (3852)73-04-60  
Белгород (4722)40-23-64  
Благовещенск (4162)22-76-07  
Брянск (4832)59-03-52  
Владивосток (423)249-28-31  
Владикавказ (8672)28-90-48  
Владимир (4922)49-43-18  
Волгоград (844)278-03-48  
Вологда (8172)26-41-59  
Воронеж (473)204-51-73  
Екатеринбург (343)384-55-89  
Иваново (4932)77-34-06  
Ижевск (3412)26-03-58  
Иркутск (395)279-98-46  
Казань (843)206-01-48

Калининград (4012)72-03-81  
Калуга (4842)92-23-67  
Кемерово (3842)65-04-62  
Киров (8332)68-02-04  
Коломна (4966)23-41-49  
Кострома (4942)77-07-48  
Краснодар (861)203-40-90  
Красноярск (391)204-63-61  
Курган (3522)50-90-47  
Курск (4712)77-13-04  
Липецк (4742)52-20-81  
Магнитогорск (3519)55-03-13  
Москва (495)268-04-70  
Мурманск (8152)59-64-93  
Набережные Челны (8552)20-53-41  
Нижний Новгород (831)429-08-12  
Новокузнецк (3843)20-46-81  
Новосибирск (383)227-86-73  
Ноябрьск (3496)41-32-12

Омск (3812)21-46-40  
Орел (4862)44-53-42  
Оренбург (3532)37-68-04  
Пенза (8412)22-31-16  
Пермь (342)205-81-47  
Петрозаводск (8142)55-98-37  
Псков (8112)59-10-37  
Ростов-на-Дону (863)308-18-15  
Рязань (4912)46-61-64  
Самара (846)206-03-16  
Санкт-Петербург (812)309-46-40  
Саранск (8342)22-96-24  
Саратов (845)249-38-78  
Севастополь (8692)22-31-93  
Симферополь (3652)67-13-56  
Смоленск (4812)29-41-54  
Сочи (862)225-72-31  
Ставрополь (8652)20-65-13  
Сургут (3462)77-98-35

Сыктывкар (8212)25-95-17  
Тамбов (4752)50-40-97  
Тверь (4822)63-31-35  
Тольятти (8482)63-91-07  
Томск (3822)98-41-53  
Тула (4872)33-79-87  
Тюмень (3452)66-21-18  
Улан-Удэ (3012)59-97-51  
Ульяновск (8422)24-23-59  
Уфа (347)229-48-12  
Хабаровск (4212)92-98-04  
Чебоксары (8352)28-53-07  
Челябинск (351)202-03-61  
Череповец (8202)49-02-64  
Чита (3022)38-34-83  
Якутск (4112)23-90-97  
Ярославль (4852)69-52-93

Россия +7(495)268-04-70

Казахстан +7(7172)727-132

Киргизия +996(312)96-26-47

<https://opti.nt-rt.ru> || [opti@nt-rt.ru](mailto:opti@nt-rt.ru)

# РАСХОДОМЕРЫ МАССОВЫЕ OPTIMASS 8000K





## OPTIMASS 8000K Technical Datasheet

Sensor for mass flow

- For gas and liquid applications up to 230°C
- Cryogenic and LNG applications down to -195°C / -319°F
- Designed to meet NAMUR installation lengths

## 1.1 The solution for extended temperature applications

A high level of performance, together with a wide operating temperature range up to 230°C, makes the OPTIMASS 8000k the ideal choice for mass flow measurement in a wide variety of applications.

Designed to meet the requirements of general purpose liquid and gas applications, the extended low temperature range of -195°C / -319°F also makes the 8000k suitable for Liquid Natural Gas (LNG) and cryogenic applications.

Combined with the power of the MFC 300, the OPTIMASS 8000k will provide accurate measurement of volume, mass, density and concentration.



- ① Comprehensive diagnostic capabilities.
- ② Standard electronics for all sensors with redundant storage of calibrated data.
- ③ Standard flange process connections available.
- ④ Modular electronics with a range of output options.



- ① Remote terminal box

## Features:

- Innovative twin U-tube design
- Temperature range -195°C to +230°C
- Optional insulation / heating jacket
- Compact envelope
- Optimised flow divider for minimum pressure loss
- Modular electronics concept: electronics and sensor are easy to replace
- Self draining when mounted vertically

## Industries:

- Fresh and waste water
- Chemical
- Oil and gas
- Food and beverage
- Pharmaceutical
- Fresh Water
- General industry
- Supercritical gases

## Applications:

- Crystallising, solidifying and cryogenic products
- Tanker loading
- General purpose applications
- CIP and SIP > 130°C
- Liquid Natural Gas (LNG)

## 1.2 Features and options

### Features



- Available as compact or remote.
- Flow rates up to 325,000 kg/h / 11940 lb/min.
- Self draining, when mounted vertically.

### Connection options



- Standard flanges with ratings up to 600 lb / PN100.
- Supports a wide range of industry standard hygienic connections.
- Optional sealing faces.
- NAMUR NE132 flange lengths

### Heating jacket and purge port

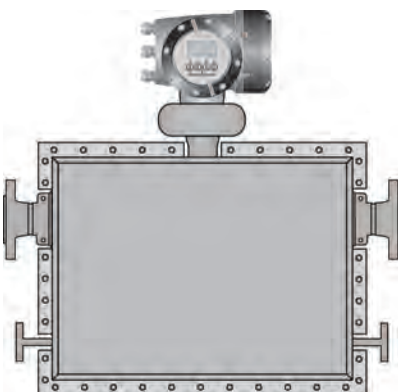

#### Heating jacket

- For use with temperature dependant products.
- Prevents solidification of process product.
- The heating case can also be used as a cryogenic insulation case.

#### Purge port

- For protection in the event of measuring tube failure.
- Allows hazardous chemicals to be drained away safely.

### 1.3 Meter / converter combinations

Converter	MFC 010	MFC 300			
Configuration	Compact	Compact	Remote field	Remote wall	Remote rack
OPTIMASS 8000k	8010kC	8300kC	8300kF	8300kW	8300kR

### 1.4 Measuring principle (twin tube)

Meter from the side, showing tube layout

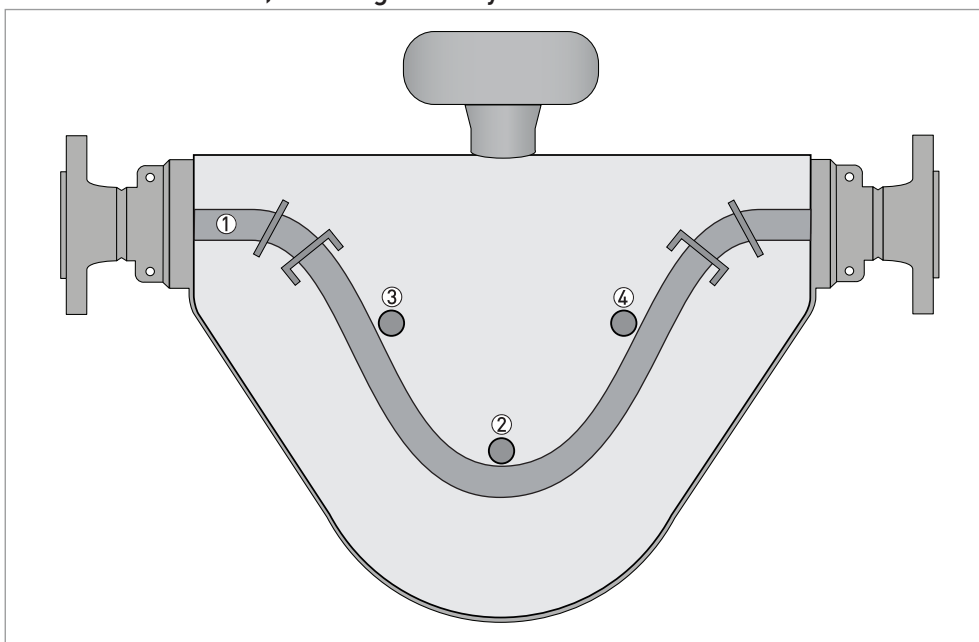

- ① Measuring tubes
- ② Drive coil
- ③ Sensor 1
- ④ Sensor 2

Static meter not energised and with no flow

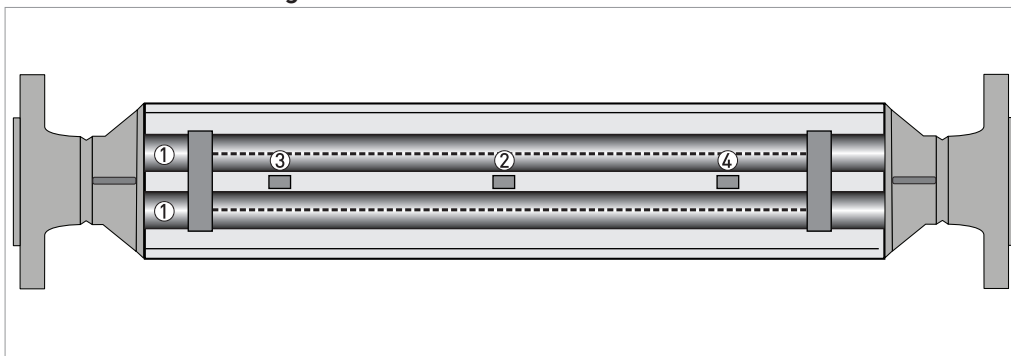

- ① Measuring tubes
- ② Drive coil
- ③ Sensor 1
- ④ Sensor 2

A Coriolis twin tube mass flowmeter consists of two measuring tubes ① a drive coil ② and two sensors (③ and ④) that are positioned either side of the drive coil.

### Energised meter

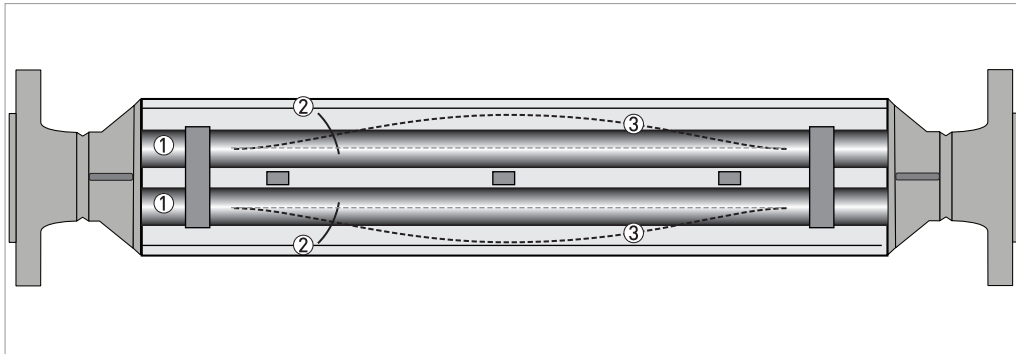

- ① Measuring tubes
- ② Direction of oscillation
- ③ Sine wave

When the meter is energised, the drive coil vibrates the measuring tubes causing them to oscillate and produce a sine wave ③. The sine wave is monitored by the two sensors.

### Energised meter with process flow

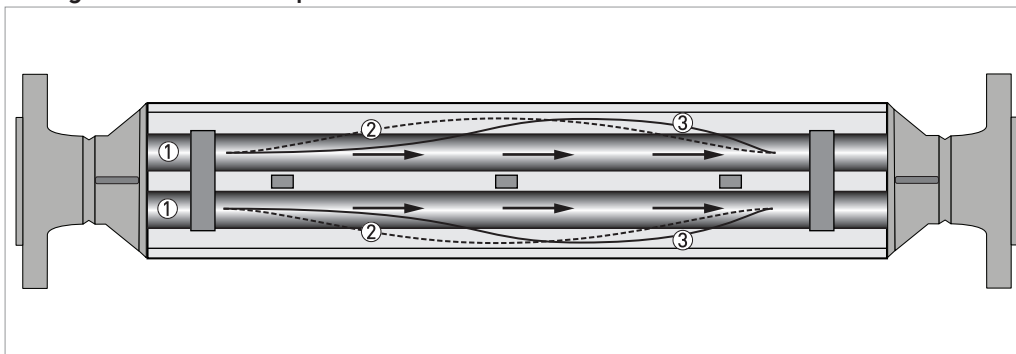

- ① Process flow
- ② Sine wave
- ③ Phase shift

When a fluid or gas passes through the tubes, the coriolis effect causes a phase shift in the sine wave that is detected by the two sensors. This phase shift is directly proportional to the mass flow.

Density measurement is made by evaluation of the frequency of vibration and temperature measurement is made using a Pt500 sensor.

## 2.1 Technical data

- *The following data is provided for general applications. If you require data that is more relevant to your specific application, please contact us or your local representative.*
- *Additional information (certificates, special tools, software,...) and complete product documentation can be downloaded free of charge from the website (Download Center).*

### Measuring system

Measuring principle	Coriolis mass flow
Application range	Mass flow and density measurement of fluids, gases and solids
Measured values	Mass, density, temperature
Calculated values	Volume, referred density, concentration, velocity

### Design

Basic	System consists of a measuring sensor and a converter to process the output signal
Features	Fully welded maintenance free sensor with twin U-shaped measuring tube
<b>Variants</b>	
Compact version	Integral converter
Remote version	Available with field, wall or 19" rack mount versions of the converter
Modbus version	Sensor with integral electronics providing Modbus output for connection to a PLC

### Measuring accuracy

<b>Mass</b>	
Liquid	$\pm 0.1\%$ of actual measured flow rate + zero stability
Gas	$\pm 0.5\%$ of actual measured flow rate + zero stability
Repeatability	Better than 0.05% plus zero stability (includes the combined effects of repeatability, linearity and hysteresis)
<b>Zero stability</b>	
Stainless Steel	$\pm 0.004\%$ of maximum flow rate with respective sensor size
<b>Reference conditions</b>	
Product	Water
Temperature	+20°C / +68°F
Operating pressure	1 barg / 14.5 psig
<b>Effect on sensor zero point caused by a shift in process temperature</b>	
Stainless Steel	0.001% of max flow per 1°C / 0.0005% per 1°F
<b>Pressure effect on mass flow rate</b>	
Stainless Steel	-0.015% per 1 barg / 0.001% per 1 psig
<b>Density</b>	
Measuring range	400...3000 kg/m <sup>3</sup> / 25...187 lbs/ft <sup>3</sup>
Accuracy	$\pm 2$ kg/m <sup>3</sup> / $\pm 0.13$ lbs/ft <sup>3</sup>
On site calibration	$\pm 0.5$ kg/m <sup>3</sup> / $\pm 0.033$ lbs/ft <sup>3</sup>
<b>Temperature</b>	
Accuracy	$\pm 1$ °C / $\pm 1.8$ °F



## Operating conditions

<b>Maximum flow rates</b>	
S15	3510 kg/h / 128.7 lbs/min
S25	11700 kg/h / 429 lbs/min
S40	41600 kg/h / 1525.3 lbs/min
S80	110500 kg/h / 4051.6 lbs/min
S100	325000 kg/h / 11916.6 lbs/min
	Assumes operating density 1000 kg/m <sup>3</sup> / 62.4 lb/ft <sup>3</sup>
<b>Ambient temperature</b>	
Compact version with Aluminium converter	Standard temperature range: -40...+60°C / -40...+140°F
	Cryogenic temperature range: -25...+40°C / -13...+104°F
Compact version with Stainless Steel converter	Standard temperature range: -40...+55°C / -40...+131°F
	Cryogenic temperature range: -25...+40°C / -13...+104°F
Remote versions	Standard temperature range: -40...+65°C / -40...+149°F
	Cryogenic temperature range: -20...+65°C / -4...+149°F
Hazardous Area versions	Refer to temperature limits
<b>Process temperature</b>	
<b>Standard temperature range</b>	
Safe area (compact and remote version)	-70...+230°C / -94...+440°F
Hazardous area (standard temperature, compact version only)	-40...+190°C / -40...+370°F
Hazardous area (standard temperature, remote version only)	-40...+230°C / -40...+440°F
Hygienic connections	-70...+150°C / -94...+302°F
<b>Cryogenic temperature range</b>	
Safe area	-195...+40°C / -310...+104°F
Hazardous area	-195...+40°C / -310...+104°F
<b>Nominal pressure at 20°C / 68°F</b>	
<b>Measuring tube</b>	
PED 97/23/EC	-1...100 barg / -14.5...1450 psig
FM	Pending
CRN / ASME B31.3	Pending
<b>Fluid properties</b>	
Permissible physical condition	Liquids, gases, slurries
Permissible gas content (volume)	Contact manufacturer for information.
Permissible solid content (volume)	Contact manufacturer for information.
Protection category (acc. to EN 60529)	IP 67, NEMA 4X
<b>Installation conditions</b>	
Inlet runs	None required
Outlet runs	None required

## Materials

Measuring tube	Stainless Steel AISI 316 / 316L (1.4401 / 1.4404) dual certified
Spigot	Stainless Steel AISI 316 / 316L (CF3M / 1.4409) dual certified
Flanges	Stainless Steel AISI 316 / 316L (1.4401 / 1.4404) dual certified
Outer casing	Stainless Steel AISI 304 (1.4301)
<b>Heating jacket version</b>	
Heating tubes and insulation jacket	Stainless Steel AISI 304 (1.4301)
<b>All versions</b>	
Sensor electronics housing	Stainless Steel 316L (1.4409)
Junction box (remote version)	Die cast Aluminium (polyurethane coating) Optional Stainless Steel 316 (1.4401)

## Process connections

<b>Flange</b>	
DIN	DN15...150 / PN40...100
ASME	½...6" / ASME 150...600
JIS	15A...100A / 10...20K
<b>Hygienic (S100 only)</b>	
Tri-clover	1...4"
Tri-clamp DIN 32676	DN25...100
Tri-clamp ISO 2852	1...4"
DIN 11864-2 Form A	DN25...100
Male thread DIN 11851	DN25...100
Male thread SMS	1...4"
Male thread IDF / ISS	1...4"
Male thread RJT	1...4"

## Electrical connections

Electrical connections	For full details, including: power supply, power consumption etc., see technical data for the relevant converter.
I/O	For full details of I/O options, including data streams and protocols, see technical data for the relevant converter.

## Approvals

<b>Mechanical</b>	
Electromagnetic compatibility (EMC) acc. to CE	Namur NE 21/5.95
	2004/108/EC (EMC)
	2006/95/EC (Low Voltage Directive)
European Pressure Equipment Directive	PED 97-23 EC (acc. to EN13445-3)
ASME	B31.3
<b>ATEX (acc. 94/9/EC)</b>	
<b>OPTIMASS 8300k C non Ex i Signal outputs</b>	
Ex d connection compartment	II 1/2 G - Ex d [ib] IIC T4...T1 Ga/Gb
	II 2 D - Ex t IIIC Txx°C Db

Ex e connection compartment	II 1/2 G - Ex de [ib] IIC T4...T1 Ga/Gb
	II 2 D - Ex t IIIC Txx°C Db
<b>OPTIMASS 8300k C Ex i signal outputs</b>	
Ex d connection compartment	II 1/2 (1) G - Ex d [ia/ib] IIC T4...T1 Ga/Gb
	II 2 (1) D - Ex t [ia Da] IIIC Txx°C Db
Ex e connection compartment	II 1/2 (1) G - Ex de [ia/ib] IIC T4...T1 Ga/Gb
	II 2 (1) D - Ex t [ia Da] IIIC Txx°C Db
<b>OPTIMASS 8000k / 8010k C</b>	II 1/2 G - Ex ib IIC T4...T1 Ga/Gb
	II 2 D - Ex t IIIC Txx°C Db

### ATEX (acc. 94/9/EC) temperature limits

	Ambient temp. $T_{amb}$ °C	Max. medium temp. $T_m$ °C	Temp. class	Max. surface temp. °C
OPTIMASS 8000k / 8010k C with or without heating jacket / insulation. Minimum process temperature $T_m$ -40°C ①	-40...+65	80	T4	T130
		140	T3	T195
		230	T2-T1	T280
OPTIMASS 8000k / 8010k C with or without heating jacket / insulation, Cryogenic Applications ①	-20...+65	-195...80	T4-T1	T130
OPTIMASS 8300k C Aluminium converter housing - with or without heating jacket / insulation. Minimum process temperature $T_m$ -40°C ①	-40...+40	60	T4	T125
		120	T3	T190
		190	T2-T1	T265
	-40...+50	120	T3	T190
		190	T2-T1	T260
	-40...+55	55	T4-T1	T125
-40...+60 ②	60	T4-T1	T130	
OPTIMASS 8300k C Stainless Steel converter housing - with or without heating jacket / insulation. Minimum process temperature $T_m$ -40°C ①	-40...+40	60	T4	T125
		120	T3	T195
		190	T2-T1	T265
	-40...+45	55	T4	T125
		190	T2-T1	T260
	-40...+50 ②	50	T4-T1	T120
OPTIMASS 8300k C Aluminium or Stainless Steel converter housing with or without heating jacket / insulation, Cryogenic Applications ①	-25...+40	-195...60	T4-T1	T125

① For sensors with additional paint coating, please refer to manufacturer

② depending on I/O option. Please call for more information.

Maximum end loadings

		S15	S25	S40	S80	S100
<b>Flanges</b>						
20°C	40 barg	25 kN	38 kN	48 kN	99 kN	150 kN
	100 barg	17 kN	19 kN	15 kN	20 kN	100 kN
230°C	32 barg	12 kN	18 kN	23 kN	45 kN	100 kN
	52 barg	10 kN			15 kN	60 kN
<b>Hygienic (all connections)</b>						
130°C	10 barg	5 kN	9 kN	12 kN	12 kN	18 kN

- These (axial) loads have been calculated, based on 316L schedule 40 process pipework, where un-radiographed butt welds have been used in pipe joints.
- The loads shown are the maximum permitted static load. If loads are cycling (between tension and compression) these loads should be reduced. For advice, consult the manufacturer.

2.2 Measuring accuracy

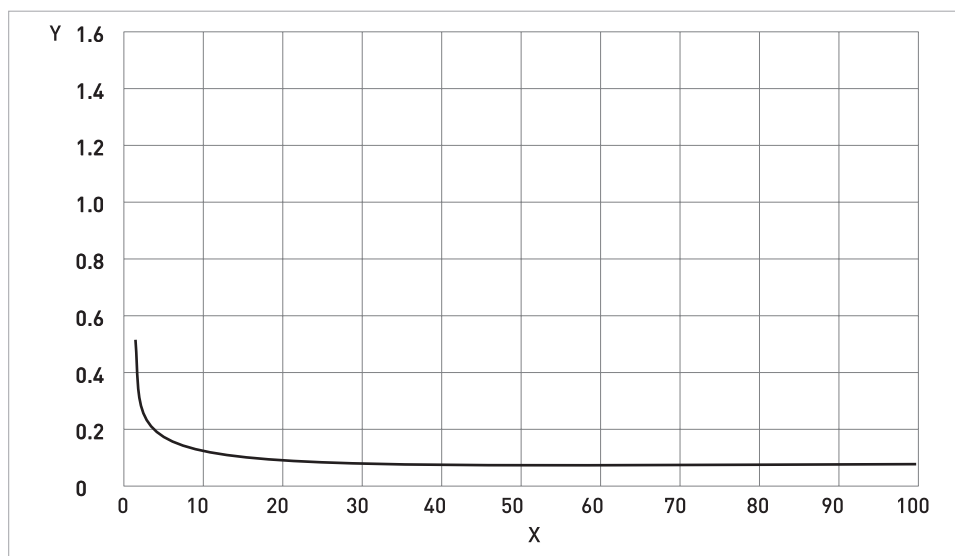

Measuring error

The measuring error is obtained from the combined effects of accuracy and zero stability.

Reference conditions

Product	Water
Temperature	+20°C / +68°F
Operating pressure	1 barg / 14.5 psig

## 2.3 Guidelines for maximum operating pressure

### Notes:

- Ensure that the meter is used within its operating limits
- All hygienic process connections have a maximum operating rating of 10 barg at 130°C / 145 psig at 266°F

### Pressure / temperature de-rating, all meter sizes in metric (flanged connections as per EN 1092-1)

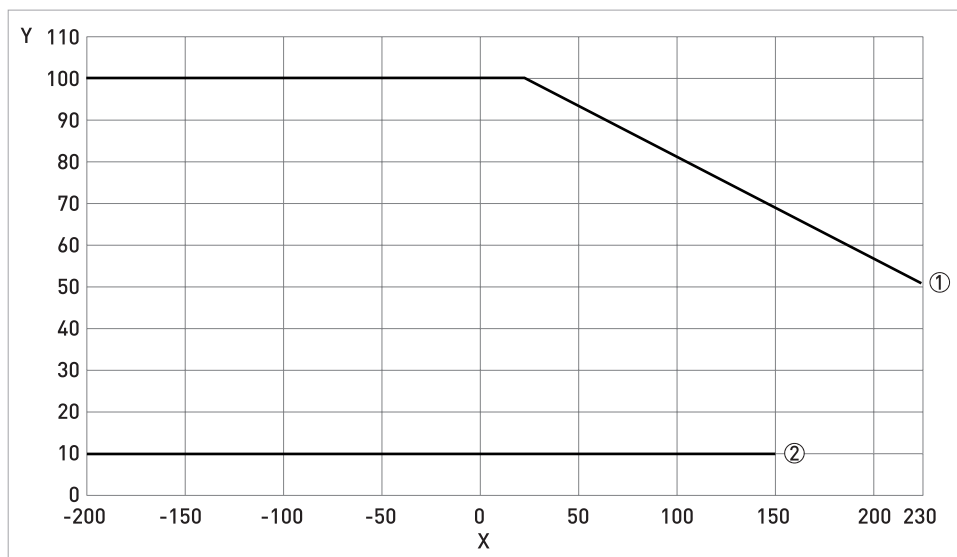

X temperature [°C]

Y pressure [barg]

① Measuring tube PED certification

② Hygienic connection

### Pressure / temperature de-rating, all meter sizes, in imperial (flanged connections as per ASME B16.5)

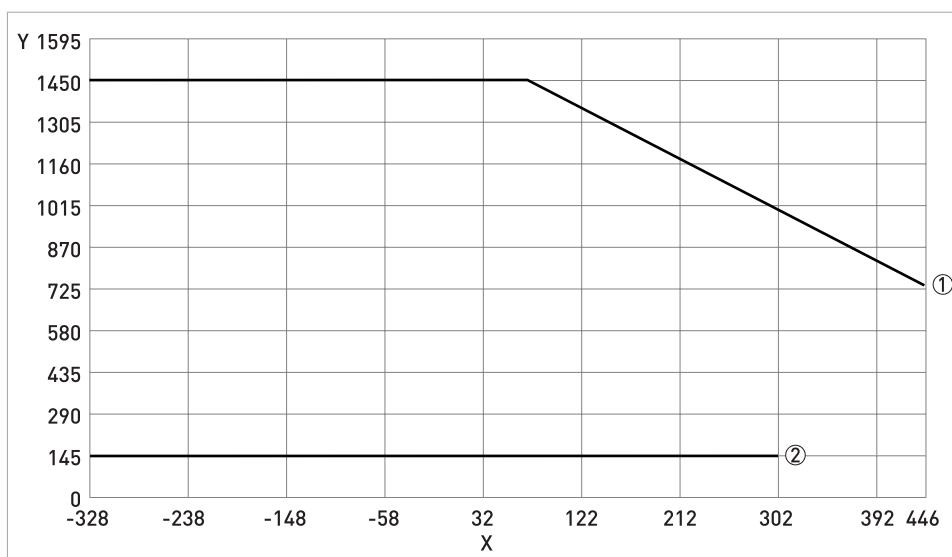

X temperature [°F]

Y pressure [psig]

- ① Measuring Tube PED certification
- ② Hygienic connection

#### Flanges

- DIN flange ratings are based on EN 1092-1 2007 table G.4.1 material group 14E0
- ASME flange ratings are based on ASME B16.5 2003 table 2 material group 2.2
- JIS flange ratings are based on JIS 2220: 2001 table 1 division 1 material group 022a

#### Notes

- The maximum operating pressure will be either the flange rating or the measuring tube rating, **WHICHEVER IS THE LOWER!**
- The manufacturer recommends that the seals are replaced at regular intervals. This will maintain the hygienic integrity of the connection.

## 2.4 Dimensions and weights

### 2.4.1 Flanged versions

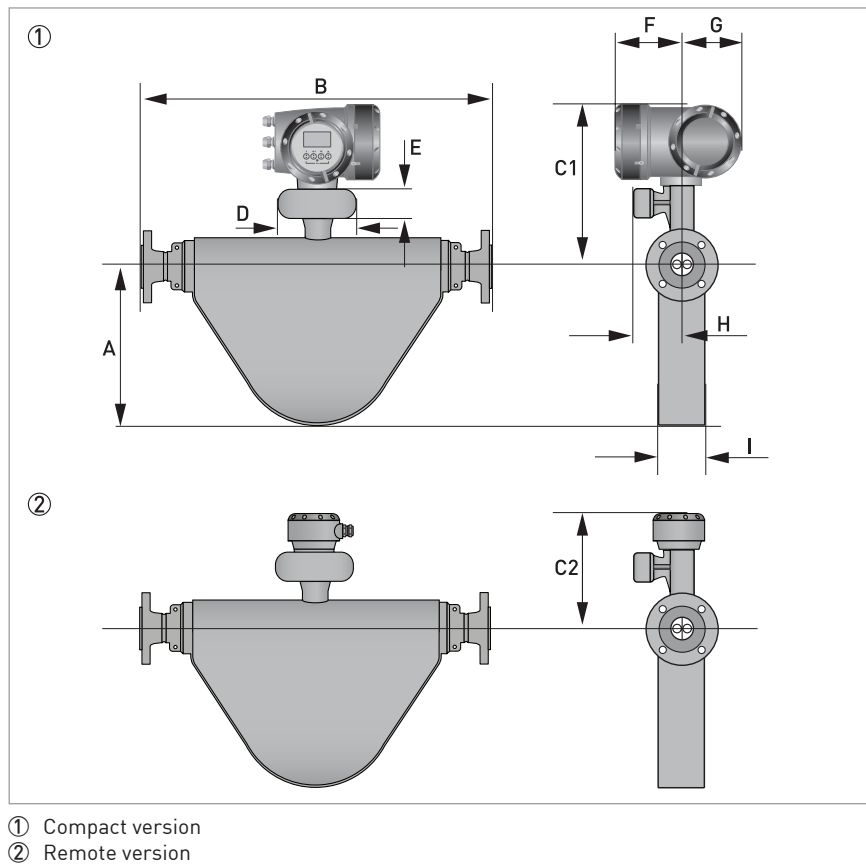

### Meter weights (all flanges)

	Weight [kg]				
	S15	S25	S40	S80	S100
Aluminium (compact)	13.8	22.3	30.8	62.3	103.8
Stainless Steel (compact)	19.2	28.4	36.9	68.4	109.9
Aluminium (remote)	11	19.5	28	59.5	101
Stainless Steel (remote)	11.8	20.3	28.8	60.3	101.8
Heating jacket add	7.5	10	11.5	16	20

	Weight [lb]				
	S15	S25	S40	S80	S100
Aluminium (compact)	30.4	49	67.8	137	228.4
Stainless Steel (compact)	42.2	62.5	81.2	150.5	241.8
Aluminium (remote)	24.2	42.9	61.6	130.9	222.2
Stainless Steel (remote)	26	44.7	63.4	132.7	224
Heating jacket add	16.5	22	25.3	35.2	44

## Measuring tube in Stainless Steel

	Dimensions [mm]				
	S15	S25	S40	S80	S100
A	185	280	320	415	450
C1 (compact)	359	374	380	407	433
C2 (remote)	282	297	303	330	356
D	160				
E	60				
F	137				
G	123.5				
H	98.5				
I	73	102	114	168	220

	Dimensions [inches]				
	S15	S25	S40	S80	S100
A	7.3	11	12.6	16.3	17.7
C1 (compact)	14.1	14.7	15	16	17
C2 (remote)	11.1	11.7	11.9	13	14
D	6.3				
E	2.4				
F	5.4				
G	4.9				
H	3.9				
I	2.9	4	4.5	6.6	8.7

## Flange connections

	Dimension B [mm]				
	S15	S25	S40	S80	S100
<b>PN40</b>					
DN15	510	-	-	-	-
DN25	512	600	-	-	-
DN40	-	608	700	-	-
DN50	-	-	715	893	-
DN80	-	-	-	915	984
DN100	-	-	-	-	998
DN150	-	-	-	-	1018
<b>PN63</b>					
DN50	-	-	741	921	-
DN80	-	-	-	943	1012
DN100	-	-	-	-	1024
DN150	-	-	-	-	1058
<b>PN100</b>					



	Dimension B [mm]				
	S15	S25	S40	S80	S100
DN15	522	-	-	-	-
DN25	548	634	-	-	-
DN40	-	642	741	-	-
DN50	-	-	753	933	-
DN80	-	-	-	953	1024
DN100	-	-	-	-	1048
DN150	-	-	-	-	1098
<b>ASME 150</b>					
½"	528	-	-	-	-
¾"	538	-	-	-	-
1"	544	518	-	-	-
1½"	-	642	741	-	-
2"	-	-	745	925	-
3"	-	-	-	937	1008
4"	-	-	-	-	1022
6"	-	-	-	-	1046
<b>ASME 300</b>					
½"	538	-	-	-	-
¾"	548	-	-	-	-
1"	556	642	--	-	-
1½"	-	656	755	-	-
2"	-	-	757	937	-
3"	-	-	-	957	1028
4"	-	-	-	-	1040
6"	-	-	-	-	1066
<b>ASME 600</b>					
½"	550	-	-	-	-
¾"	560	-	-	-	-
1"	568	656	-	-	-
1½"	-	670	771	-	-
2"	-	-	775	957	-
3"	-	-	-	975	1046
4"	-	-	-	-	1086
6"	-	-	-	-	1116
<b>JIS 10K</b>					
50A	-	-	706	893	-
80A	-	-	-	913	-
<b>JIS 20K</b>					
15A	508	-	-	-	-
25A	512	598	-	-	-
40A	-	608	707	-	-

	Dimension B [mm]				
	S15	S25	S40	S80	S100
50A	-	-	713	893	-
80A	-	-	-	913	-
100A	-	-	-	-	1020

	Dimension B [inches]				
	S15	S25	S40	S80	S100
<b>PN40</b>					
DN15	20	-	-	-	-
DN25	20.2	23.5	-	-	-
DN40	-	24	27.8	-	-
DN50	-	-	28	35.2	-
DN80	-	-	-	36	38.7
DN100	-	-	-	-	39.3
DN150	-	-	-	-	40.2
<b>PN63</b>					
DN50	-	-	29	-	-
DN80	-	-	-	37	39.8
DN100	-	-	-	-	40.3
DN150	-	-	-	-	41.6
<b>PN100</b>					
DN15	20.5	-	-	-	-
DN25	21.6	25	-	-	-
DN40	-	25.3	28.9	-	-
DN50	-	-	29.4	36.7	-
DN80	-	-	-	37.5	40.3
DN100	-	-	-	-	41.3
DN150	-	-	-	-	43.2
<b>ASME 150</b>					
½"	20.8	-	-	-	-
¾"	21.2	-	-	-	-
1"	21.4	20.4	-	-	-
1½"	-	25.3	29.2	-	-
2"	-	-	29.3	36.4	-
3"	-	-	-	36.9	39.7
4"	-	-	-	-	40.2
6"	-	-	-	-	41.3
<b>ASME 300</b>					
½"	21.2	-	-	-	-
¾"	21.6	-	-	-	-
1"	21.9	25.3	--	-	-

	Dimension B [inches]				
	S15	S25	S40	S80	S100
1½"	-	25.8	29.7	-	-
2"	-	-	29.8	36.9	-
3"	-	-	-	37.7	40.5
4"	-	-	-	-	41
6"	-	-	-	-	42
<b>ASME 600</b>					
½	21.6	-	-	-	-
¾"	22	-	-	-	-
1"	22.4	25.8	-	-	-
1½"	-	26.4	30.4	-	-
2"	-	-	30.5	37.7	-
3"	-	-	-	38.4	41.2
4"	-	-	-	-	42.8
6"	-	-	-	-	44
<b>JIS 10K</b>					
50A	-	-	28	35.2	-
80A	-	-	-	35.9	-
<b>JIS 20K</b>					
15A	20	-	-	-	-
25A	20.2	23.5	-	-	-
40A	-	23.9	27.8	-	-
50A	-	-	28	35.1	-
80A	-	-	-	35.9	-
100A	-	-	-	-	40.2

## 2.4.2 NAMUR dimensions

The following face to face dimensions comply with NAMUR NE132

PN40	Dimensions [mm +0.0 / -5.0]				
	S15	S25	S40	S80	S100
DN 15	510	-	-	-	-
DN 25	-	600	-	-	-
DN 50	-	-	715	-	-
DN 80	-	-	-	915	-
<b>Dimensions [inches +0.0 / -0.12]</b>					
DN 15	20.1	-	-	-	-
DN 25	-	23.6	-	-	-
DN 50	-	-	28.1	-	-
DN 80	-	-	-	36	-

## 2.4.3 Hygienic versions

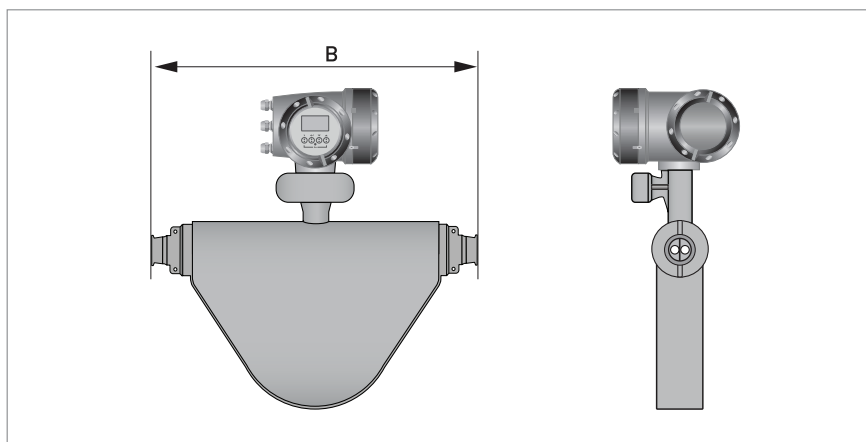

## Hygienic connections: all welded versions

	Dimension B [mm]				
	S15	S25	S40	S80	S100
<b>Tri-clover</b>					
1"	485	-	-	-	-
1½"	-	580	-	-	-
2"	-	-	675	-	-
3"	-	-	-	850	-
4"	-	-	-	-	911
<b>Tri-clamp DIN 32676</b>					
DN25	475	-	-	-	-
DN40	-	570	-	-	-
DN50	-	-	668	-	-
DN80	-	-	-	859	-
DN100	-	-	-	-	924
<b>Tri-clamp ISO 2852</b>					
1"	481	-	-	-	-
1½"	-	586	-	-	-
2"	-	-	666	-	-
3"	-	-	-	846	-
4"	-	-	-	-	911
<b>DIN 11864-2 Form A (Female)</b>					
DN25	512	-	-	-	-
DN40	-	617	-	-	-
DN50	-	-	715	-	-
DN80	-	-	-	919	-
DN100	-	-	-	-	984

	Dimension B [inches]				
	S15	S25	S40	S80	S100
<b>Tri-clover</b>					
1"	19	-	-	-	-
1½"	-	23	-	-	-
2"	-	-	26.6	-	-
3"	-	-	-	33.5	-
4"	-	-	-	-	36
<b>Tri-clamp DIN 32676</b>					
DN25	19	-	-	-	-
DN40	-	22.5	-	-	-
DN50	-	-	26.3	-	-
DN80	-	-	-	34	-
DN100	-	-	-	-	36.4
<b>Tri-clamp ISO 2852</b>					
1"	19	-	-	-	-
1½"	-	23	-	-	-
2"	-	-	26.2	-	-
3"	-	-	-	33.3	-
4"	-	-	-	-	36
<b>DIN 11864-2 Form A (Female)</b>					
DN25	20	-	-	-	-
DN40	-	24.3	-	-	-
DN50	-	-	28.2	-	-
DN80	-	-	-	36	-
DN100	-	-	-	-	38.7

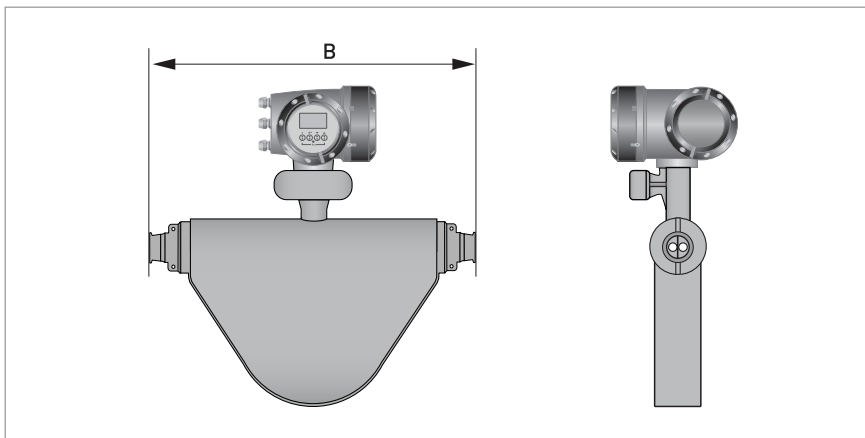

Hygienic connections: adapter versions (male thread)

	Dimension B [mm]				
	S15	S25	S40	S80	S100
<b>Male thread DIN 11851</b>					
DN25	490	-	-	-	-
DN40	-	593	-	-	-
DN50	-	-	695	-	-
DN80	-	-	-	893	-
DN100	-	-	-	-	976
<b>Male thread SMS</b>					
1"	472	-	-	-	-
1½"	-	583	-	-	-
2"	-	-	678	-	-
3"	-	-	-	855	-
4"	-	-	-	-	924
<b>Male thread IDF/ISS</b>					
1"	485	-	-	-	-
1½"	-	580	-	-	-
2"	-	-	675	-	-
3"	-	-	-	850	-
4"	-	-	-	-	911
<b>Male thread RJT</b>					
1"	496	-	-	-	-
1½"	-	591	-	-	-
2"	-	-	686	-	-
3"	-	-	-	861	-
4"	-	-	-	-	922

	Dimension B [inches]				
	S15	S25	S40	S80	S100
<b>Male thread DIN 11851</b>					
DN25	19.3	-	-	-	-
DN40	-	23.3	-	-	-
DN50	-	-	27.4	-	-
DN80	-	-	-	35	-
DN100	-	-	-	-	38.4
<b>Male thread SMS</b>					
1"	18.6	-	-	-	-
1½"	-	23	-	-	-
2"	-	-	26.7	-	-
3"	-	-	-	33.7	-
4"	-	-	-	-	36.4
<b>Male thread IDF/ISS</b>					
1"	19	-	-	-	-
1½"	-	22.8	-	-	-
2"	-	-	26.6	-	-
3"	-	-	-	33.5	-
4"	-	-	-	-	35.9
<b>Male thread RJT</b>					
1"	19.5	-	-	-	-
1½"	-	23.3	-	-	-
2"	-	-	27	-	-
3"	-	-	-	33.4	-
4"	-	-	-	-	36.3

2.4.4 Heating jacket version

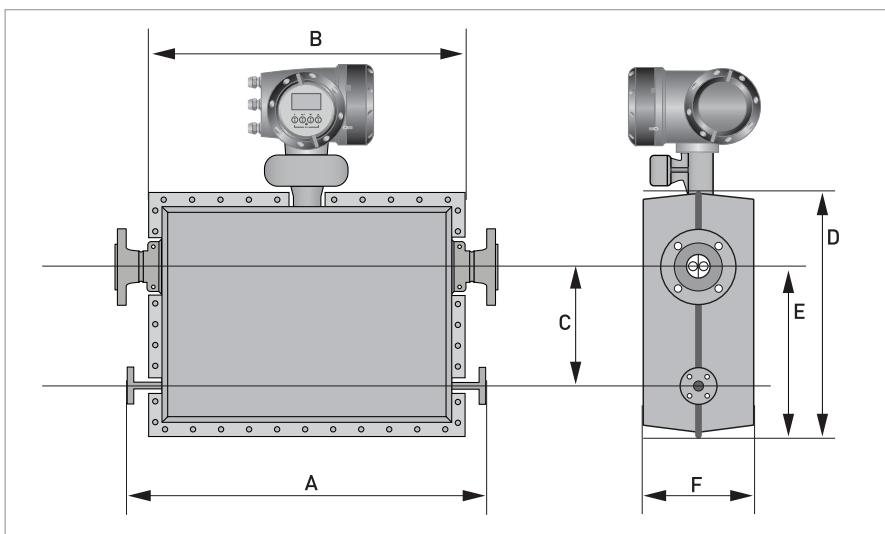

	Dimensions [mm]				
	S15	S25	S40	S80	S100
Heating connection size	PN40 DN25 or ASME 150 ½"				
A	590 ±5.0	692 ±5.0	715 ±5.0	891 ±5.0	956 ±5.0
B	440 ±3.0	542 ±3.0	565 ±3.0	741 ±3.0	806 ±3.0
C	130 ±3.0	210 ±3.0	230 ±3.0	320 ±3.0	340 ±3.0
D	344 ±3.0	453 ±3.0	499 ±3.0	622 ±3.0	682 ±3.0
E	221 ±3.0	316 ±3.0	356 ±3.0	451 ±3.0	486 ±3.0
F	226 ±3.0	254 ±3.0	266 ±3.0	322 ±3.0	372 ±3.0

	Dimensions [inches]				
	S15	S25	S40	S80	S100
Heating connection size	PN40 DN25 or ASME 150 ½"				
A	23.2±0.2	27.2 ±0.2	28 ±0.2	891 ±0.2	37.6 ±0.2
B	17.3 ±0.12	21.3 ±0.12	22.2 ±0.12	29 ±0.12	31.7 ±0.12
C	5 ±0.12	8.7 ±0.12	9 ±0.12	12.6 ±0.12	13.4 ±0.12
D	13.5 ±0.12	17.8 ±0.12	19.6 ±0.12	24.5 ±0.12	26.9 ±0.12
E	8.7 ±0.12	12.4 ±0.12	14 ±0.12	17.7 ±0.12	19.1 ±0.12
F	8.9 ±0.12	10 ±0.12	10.5 ±0.12	12.7 ±0.12	14.6 ±0.12



## 2.4.5 Purge port option

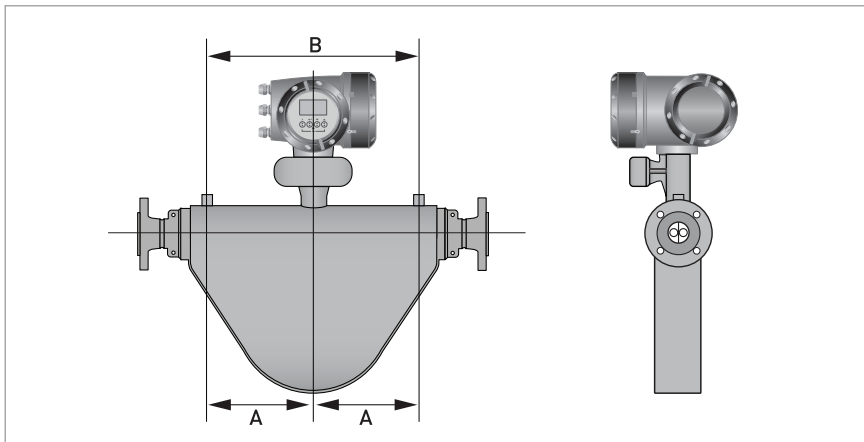

	Dimensions [mm]				
	S15	S25	S40	S80	S100
A	150	200	215	300	305
B	300	400	430	600	610

	Dimensions [inches]				
	S15	S25	S40	S80	S100
A	5.9	7.9	8.5	11.8	12
B	11.8	15.7	17	23.6	24

## 3.1 Intended use

This mass flowmeter is designed for the direct measurement of mass flow rate, product density and product temperature. Indirectly, it also enables the measurement of parameters like total mass, concentration of dissolved substances and the volume flow. For use in hazardous areas, special codes and regulations are also applicable and these are specified in a separate documentation.

## 3.2 Mounting restrictions

### 3.2.1 General installation principles

**There are no special installation requirements but you should note the following points:**

- Support the weight of the meter as close to the meter body as possible.
- Mount the meter in such a way to avoid the build up of gas or liquid in the measuring tube.
- No straight runs are required.
- The use of reducers and other fittings at flanges, including flexible hoses, is allowed but you should take care to avoid cavitation.
- Avoid extreme pipe size reductions.
- Meters are not affected by crosstalk and can be mounted in series or in parallel.
- Avoid mounting the meter at the highest point in the pipeline where air / gas can collect.

### Mounting positions

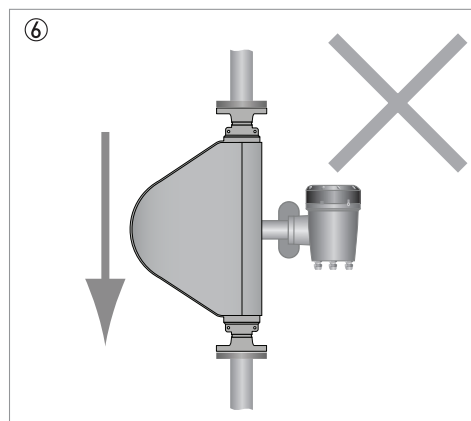
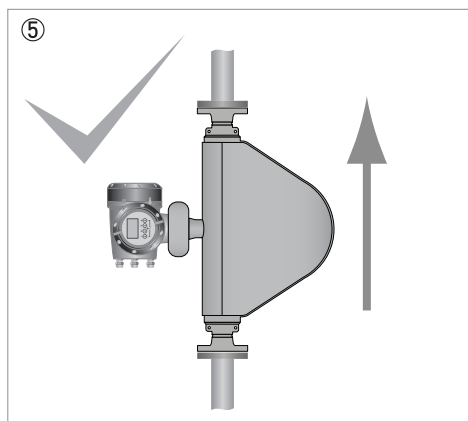
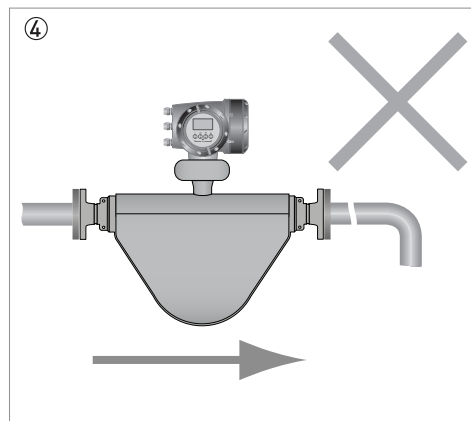
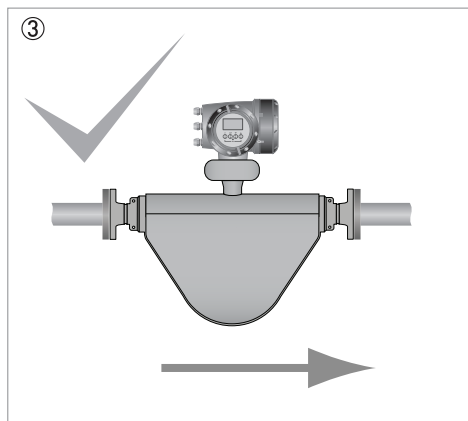
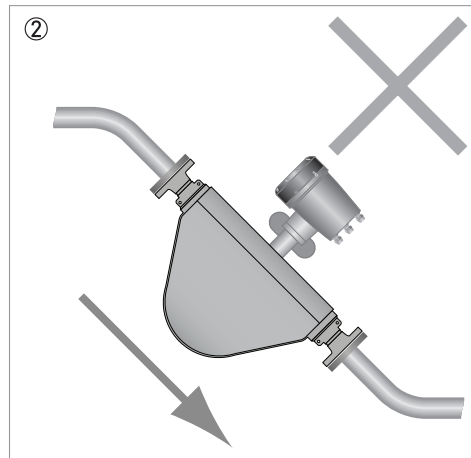
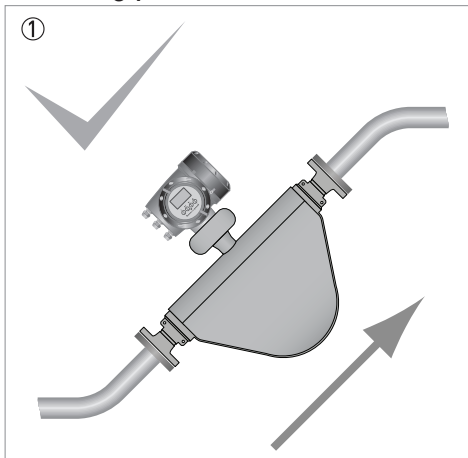

- ① The meter can be mounted at an angle but it is recommended that the flow is uphill.
- ② Avoid mounting the meter with the flow running downhill because it can cause siphoning. If the meter has to be mounted with the flow running downhill, install an orifice plate or control valve downstream of the meter to maintain backpressure.
- ③ Horizontal mounting with flow running left to right.
- ④ Avoid mounting meter with long vertical runs after the meter as it can cause cavitation. Where the installation includes a vertical run after the meter, install an orifice plate or control valve downstream to maintain backpressure.
- ⑤ The meter can be mounted vertically but it is recommended that the flow is uphill.
- ⑥ Avoid mounting the meter vertically with the flow running downhill. This can cause siphoning. If the meter has to be installed this way, install an orifice plate or control valve downstream to maintain backpressure.

Comprehensive installation guidance is provided in the Handbook

## 4.1 Safety instructions

*All work on the electrical connections may only be carried out with the power disconnected. Take note of the voltage data on the nameplate!*

*Observe the national regulations for electrical installations!*

*For devices used in hazardous areas, additional safety notes apply; please refer to the Ex documentation.*

*Observe without fail the local occupational health and safety regulations. Any work done on the electrical components of the measuring device may only be carried out by properly trained specialists.*

*Look at the device nameplate to ensure that the device is delivered according to your order. Check for the correct supply voltage printed on the nameplate.*

## 4.2 Electrical and I/O connections

For information regarding electrical and I/O connections, please refer to the handbook for the relevant signal converter.

**Алматы** (7273)495-231  
**Ангарск** (3955)60-70-56  
**Архангельск** (8182)63-90-72  
**Астрахань** (8512)99-46-04  
**Барнаул** (3852)73-04-60  
**Белгород** (4722)40-23-64  
**Благовещенск** (4162)22-76-07  
**Брянск** (4832)59-03-52  
**Владивосток** (423)249-28-31  
**Владикавказ** (8672)28-90-48  
**Владимир** (4922)49-43-18  
**Волгоград** (844)278-03-48  
**Вологда** (8172)26-41-59  
**Воронеж** (473)204-51-73  
**Екатеринбург** (343)384-55-89  
**Иваново** (4932)77-34-06  
**Ижевск** (3412)26-03-58  
**Иркутск** (395)279-98-46  
**Казань** (843)206-01-48

**Калининград** (4012)72-03-81  
**Калуга** (4842)92-23-67  
**Кемерово** (3842)65-04-62  
**Киров** (8332)68-02-04  
**Коломна** (4966)23-41-49  
**Кострома** (4942)77-07-48  
**Краснодар** (861)203-40-90  
**Красноярск** (391)204-63-61  
**Курган** (3522)50-90-47  
**Курск** (4712)77-13-04  
**Липецк** (4742)52-20-81  
**Магнитогорск** (3519)55-03-13  
**Москва** (495)268-04-70  
**Мурманск** (8152)59-64-93  
**Набережные Челны** (8552)20-53-41  
**Нижний Новгород** (831)429-08-12  
**Новокузнецк** (3843)20-46-81  
**Новосибирск** (383)227-86-73  
**Ноябрьск**(3496)41-32-12

**Омск** (3812)21-46-40  
**Орел** (4862)44-53-42  
**Оренбург** (3532)37-68-04  
**Пенза** (8412)22-31-16  
**Пермь** (342)205-81-47  
**Петрозаводск** (8142)55-98-37  
**Псков** (8112)59-10-37  
**Ростов-на-Дону** (863)308-18-15  
**Рязань** (4912)46-61-64  
**Самара** (846)206-03-16  
**Санкт-Петербург** (812)309-46-40  
**Саранск** (8342)22-96-24  
**Саратов** (845)249-38-78  
**Севастополь** (8692)22-31-93  
**Симферополь** (3652)67-13-56  
**Смоленск** (4812)29-41-54  
**Сочи** (862)225-72-31  
**Ставрополь** (8652)20-65-13  
**Сургут** (3462)77-98-35

**Сыктывкар** (8212)25-95-17  
**Тамбов** (4752)50-40-97  
**Тверь** (4822)63-31-35  
**Тольятти** (8482)63-91-07  
**Томск** (3822)98-41-53  
**Тула** (4872)33-79-87  
**Тюмень** (3452)66-21-18  
**Улан-Удэ** (3012)59-97-51  
**Ульяновск** (8422)24-23-59  
**Уфа** (347)229-48-12  
**Хабаровск** (4212)92-98-04  
**Чебоксары** (8352)28-53-07  
**Челябинск** (351)202-03-61  
**Череповец** (8202)49-02-64  
**Чита** (3022)38-34-83  
**Якутск** (4112)23-90-97  
**Ярославль** (4852)69-52-93

**Россия** +7(495)268-04-70

**Казахстан** +7(7172)727-132

**Киргизия** +996(312)96-26-47

<https://opti.nt-rt.ru> || [opti@nt-rt.ru](mailto:opti@nt-rt.ru)