

Алматы (7273)495-231
Ангарск (3955)60-70-56
Архангельск (8182)63-90-72
Астрахань (8512)99-46-04
Барнаул (3852)73-04-60
Белгород (4722)40-23-64
Благовещенск (4162)22-76-07
Брянск (4832)59-03-52
Владивосток (423)249-28-31
Владикавказ (8672)28-90-48
Владимир (4922)49-43-18
Волгоград (844)278-03-48
Вологда (8172)26-41-59
Воронеж (473)204-51-73
Екатеринбург (343)384-55-89
Иваново (4932)77-34-06
Ижевск (3412)26-03-58
Иркутск (395)279-98-46
Казань (843)206-01-48

Калининград (4012)72-03-81
Калуга (4842)92-23-67
Кемерово (3842)65-04-62
Киров (8332)68-02-04
Коломна (4966)23-41-49
Кострома (4942)77-07-48
Краснодар (861)203-40-90
Красноярск (391)204-63-61
Курган (3522)50-90-47
Курск (4712)77-13-04
Липецк (4742)52-20-81
Магнитогорск (3519)55-03-13
Москва (495)268-04-70
Мурманск (8152)59-64-93
Набережные Челны (8552)20-53-41
Нижний Новгород (831)429-08-12
Новокузнецк (3843)20-46-81
Новосибирск (383)227-86-73
Ноябрьск(3496)41-32-12

Омск (3812)21-46-40
Орел (4862)44-53-42
Оренбург (3532)37-68-04
Пенза (8412)22-31-16
Пермь (342)205-81-47
Петрозаводск (8142)55-98-37
Псков (8112)59-10-37
Ростов-на-Дону (863)308-18-15
Рязань (4912)46-61-64
Самара (846)206-03-16
Санкт-Петербург (812)309-46-40
Саранск (8342)22-96-24
Саратов (845)249-38-78
Севастополь (8692)22-31-93
Симферополь (3652)67-13-56
Смоленск (4812)29-41-54
Сочи (862)225-72-31
Ставрополь (8652)20-65-13
Сургут (3462)77-98-35

Сыктывкар (8212)25-95-17
Тамбов (4752)50-40-97
Тверь (4822)63-31-35
Тольятти (8482)63-91-07
Томск (3822)98-41-53
Тула (4872)33-79-87
Тюмень (3452)66-21-18
Улан-Удэ (3012)59-97-51
Ульяновск (8422)24-23-59
Уфа (347)229-48-12
Хабаровск (4212)92-98-04
Чебоксары (8352)28-53-07
Челябинск (351)202-03-61
Череповец (8202)49-02-64
Чита (3022)38-34-83
Якутск (4112)23-90-97
Ярославль (4852)69-52-93

Россия +7(495)268-04-70

Казахстан +7(7172)727-132

Киргизия +996(312)96-26-47

<https://opti.nt-rt.ru> || opti@nt-rt.ru

РОТАМЕТРЫ

H250 M8



1.1 The standard solution for the process industry

The all-metal variable area flowmeter H250 is used for flow measurement of conductive and non-conductive liquids and gases.

Highlights

- Simple, low-cost installation: Measurement and indication without auxiliary power supply
- Very compact indicator housing for space-saving installation
- Optional limit switch for flow monitoring or continuous 4...20 mA measuring signal
- Many connection variants: flanged, screwed, clamped, weld-on ends
- Choice of material: stainless steel, Hastelloy[®], titanium, Monel, Inconel
- High application safety, even with extremely low flows
- Intrinsically safe for use in hazardous areas

Industries

Can be used in all industrial sectors, for example:

- Chemical
- Petrochemical
- Pharmaceuticals
- Machinery
- Food & Beverage
- Oil & Gas
- Iron, Steel & Metal
- Power plants
- Paper & Pulp
- Water & wastewater industries

Applications:

- Nitrogen inerting to avoid explosive atmospheres
- Measurement of additives such as catalysts, tensides, anti-foaming and anti-corrosion agents
- Measurement of chlorine, sulphur and ethylene compounds
- Measurement of distilled or demineralised water
- Monitoring of lubricating and cooling agents for process pumps and rotating machines
- Monitoring of sealing systems on compressors
- Gas measurement for industrial furnaces

1.2 Options and variants

Indicator M8 (compact)



- Compact, space-saving design

M8M

- Mechanical indicator without auxiliary power
- 2 limit switches (NAMUR)

M8E

- Electronic bargraph indicator
- 2-wire current output 4...20 mA with HART®

For particularly rough environmental conditions, the M8 indicator housing is optionally available in stainless steel.

This guarantees its reliable use in corrosive atmospheres caused by operational emissions.

When installed outdoors, external influences such as salt fog or contaminated precipitation no longer lead to corrosion.

1.3 Functional principle

The flowmeter operates in accordance with the float measuring principle. The measuring unit consists of a metal cone in which a float can move freely up and down. The medium flows through the flowmeter from bottom to top. The float changes position so that the lifting force acting on it A is in equilibrium with the form drag W and its weight G : $G = A + W$.

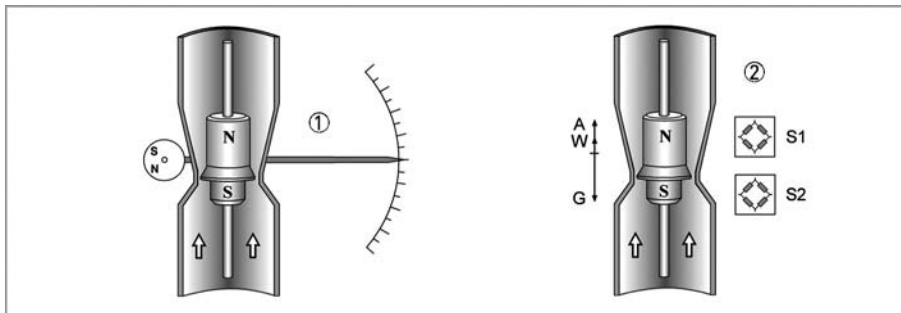

Figure 1-1: Functional principle

1 Indication principle M8MG 2

Indication principle M8EG

For the indicator M8MG 1 the flow-dependent height of the float in the measuring unit is transmitted by means of a magnetic coupling and displayed on a scale. For the indicator M8EG 2 the flow-dependent height of the float in the measuring unit is transmitted to the electronic display by means of a magnetic coupling on sensors S1 and S2.

2.1 Technical data

- The following data is provided for general applications. If you require data that is more relevant to your specific application, please contact us or your local sales office.
- Additional information (certificates, special tools, software,...) and complete product documentation can be downloaded free of charge from the website (Downloadcenter).

Measuring system

Scope of application	Flow measurement of liquids and gases
Function / Measuring principle	Float measuring principle
Measured value	
Primary measured value	Float position
Secondary measured value	Operating and standard volume flow

Measuring accuracy

Directive	VDI/VDE 3513, sheet 2 ($q_G = 50\%$)
H250/RR & H250/HC	1.6%

Operating conditions

Temperature	
Max. operating temperature TS	-196...+200°C / -321...+392°F
Pressure	
Max. operating pressure PS	Depending on the version up to 400 barg / 5802 psig
Max. test pressure PT	Depending on the version (refer to nameplate)
Min. required operating pressure	2 times greater than pressure loss (refer to measuring ranges)
Float damping during gas measurement recommended	
DN15...25 / 1/2...1"	Operating pressure <0.3 barg / 4.4 psig
Ingress protection	
Indicator in PPS	IP66
Indicator in stainless steel	IP66 / IP67

Installation conditions

Inlet section	$\geq 5 \times$
Outlet section	$\geq 3 \times$ DN

Materials

H250/RR

Flange, measuring tube, float and float guide	Stainless steel CrNi 1.4404 / 316L
---	------------------------------------

H250/HC

Flange	Hastelloy® C4 / 2.4610 solid or plated
Measuring tube, float and float guide	Hastelloy® C4

Indicator

M8MG, M8EG	PPS
M8MG/R, M8EG/R	Stainless steel 1.4408/CF8M

Other options:

- Special materials on request: e.g. SMO 254, titanium, 1.4435
- Gasket for devices with female thread as insert: O-ring FPM/FKM

~~Temperatures~~

For devices to be used in hazardous areas, special temperature ranges apply. These can be found in the supplementary instructions.

Temperatures

	[°C]	[°F]
--	------	------

M8M

Product temperature T_m without limit switches	-80...+200	-112...+392
Product temperature T_m with limit switches	-40...+200	-40...+392
Ambient temperature $T_{amb.}$	-40...+70	-40...+158

M8E

Product temperature T_m at $T_{amb.}$ +40°C / +104°F	-40...+200	-40...+392
Product temperature T_m at $T_{amb.}$ +50°C / +122°F	-40...+185	-40...+365
Product temperature T_m at $T_{amb.}$ +60°C / +140°F	-40...+145	-40...+293
Ambient temperature $T_{amb.}$	-40...+70	-40...+158

M8M limit switches

Terminal connection	2.5 mm ²	
Limit switches	I7S2002-N SC2-N0	SJ2-SN
Type	2-wire NAMUR	2-wire NAMUR 1
Switching element function	Normally closed	Normally closed
Nominal voltage U_0	8 VDC	8 VDC
Pointer vane not detected	≥ 3 mA	≥ 3 mA
Pointer vane detected	≤ 1 mA	≤ 1 mA

1 Safety-oriented

M8E current output

Cable gland	M16 x 1.5
Cable diameter	8...10 mm / 0.315...0.394
Terminal connection	4 mm ²
Measuring signal	4...20 mA = 0...100% flow value in 2-wire technology
Power supply	14.8...30 VDC
Min. power supply for HART®	20.5 VDC
Power supply influence	<0.1%
External resistance dependency	<0.1%
Temperature influence	<10 µA/K
Max. external resistance / load	650 Ω at 30 VDC
Min. load for HART®	250 Ω
Software firmware version	01.15
Identification number	3204090400

M8E HART® configuration

Manufacturer name (code)	Messtechnik (0x45 = 69)
Model name	M8E (230)
HART® revision	5.1
Device revision	1
Physical Layer	FSK
Device category	Transmitter

M8E process variable

M8E process variable, flow rate	Values [%]	Signal output [mA]
Upper range limit	+102.5 (±1%)	20.24...20.56
Device error detection	>106.25	≥21.00
Maximum	112.5	22
Multi-Drop operation	-	4.5
Min. U _{ext.}	14.8 VDC	

Approvals

Standard	Indicator	Marking
ATEX / IECEx	M8 mechanical	II2G Ex h IIC T6...T3 Gb II2D Ex h IIIC T200°C Db
	M8 electrical	II2G Ex ia IIC T6...T3 Gb II2D Ex ia IIIC T75°C...T200°C Db (M8xG/R)
QPS	M8	IS/I/1/ABCD/T6 I/AEx ia/IIC/T6

2.2 Dimensions and weight

Dimensions

Front view

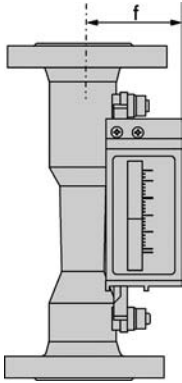

Side view

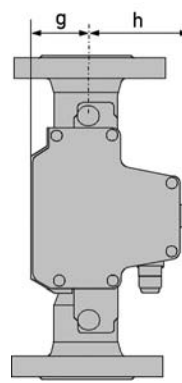

		Dimensions M8M						Dimensions M8E					
		f		g		h		f		g		h	
EN	ASME	[mm]	["]	[mm]	["]	[mm]	["]	[mm]	["]	[mm]	["]	[mm]	["]
DN15	1/2"	63	2.48	60	2.36	58.5	2.30	53.5	2.11	66	2.60	52.5	2.07
DN25	1"	75	2.95	60	2.36	58.5	2.30	65.5	2.58	66	2.60	52.5	2.07

Overall height

	[mm]	["]
Flange	250	9.85
ISO 228 / ASME B1.20.1	300	11.82

Weights

Nominal size		Indicator in PPS		Indicator in stainless steel	
EN	ASME	[kg]	[lb]	[kg]	[lb]
DN15	1/2"	3.5	7.7	4.8	10.6
DN25	1"	5	11	6.3	13.9

Process connections

	Standard	Conn. dim.	Pressure rating
Flanges (H250/RR & H250/HC)	EN 1092-1	DN15...50	PN16...250
	ASME B16.5	1/2...3"	150...2500 lb
Clamp connections (H250/RR)	DIN 32676	DN25...40	10...16 bar
	ISO 2852	NS 25...40	10...16 bar
Screw connections (H250/RR & H250/HC)	DIN 11851	DN25...40	25...40 bar
	SMS 1146	1"	6 barg / 88.2 psig
Female thread welded (H250/RR & H250/HC)	ISO 228	G1/2...2	≥ 50 barg / 735 psig
	ASME B1.20.1	1/2...2 NPT	
Female thread (H250/RR & H250/HC) with insert, FPM gasket and union nut	ISO 228	G1/2...2	≤ 50 barg / 735 psig
	ASME B1.20.1	1/2...2 NPT	

Higher pressure ratings and other connections on request.

2.3 Measuring ranges

H250/RR - stainless steel, H250/HC - Hastelloy®

Measuring span:	10 : 1		
Flow values:	Values = 100%	Water: +20°C / +68°F	Air: +20°C / +68°F, 1.013 bara / 14.7 psia

Float ▶		Water			Air			Max. pressure loss			
		TIV	CIV	DIV	TIV Alu.	TIV	DIV	TIV Alu.	TIV	CIV	DIV
Nominal size	Cone	[l/h]			[Nm ³ /h]			[mbar]			
DN15, 1/2"	K 15.1	18	25	-	0.42	0.65	-	12	21	26	-
	K 15.2	30	40	-	0.7	1	-	12	21	26	-
	K 15.3	55	63	-	1	1.5	-	12	21	26	-
	K 15.4	80	100	-	1.7	2.2	-	12	21	26	-
	K 15.5	120	160	-	2.5	3.6	-	12	21	26	-
	K 15.6	200	250	-	4.2	5.5	-	12	21	26	-
	K 15.7	350	400	700	6.7	10	18 ①	12	21	28	38
	K 15.8	500	630	1000	10	14	28 ①	13	22	32	50
DN25, 1"	K 15.8	-	-	1600 ②	-	-	50 ②	-	-	-	85
	K 25.1	480	630	1000	9.5	14	-	11	24	32	72
	K 25.2	820	1000	1600	15	23	-	11	24	33	74
	K 25.3	1200	1600	2500	22	35	-	11	25	34	75
	K 25.4	1700	2500	4000	37	50	110 ①	12	26	38	78
	K 25.5	3200	4000	6300	62	95	180 ①	13	30	45	103 ③

① P > 0.5 bar

② with TR float

③ 300 mbar with damping (gas measurement)

The operating pressure should be at least double the pressure loss for liquids and five times for gases. The indicated pressure losses are valid for water and air at maximum flow rate. Other flow ranges on request. Conversion of other media or operating data is performed using the calculation method in accordance with VDI/VDE directive 3513.

Reference condition for gas measurements:

Flow measurements for gases are attributed to NI/h or Nm³/h:

Volume flow at standard (norm.) conditions 0°C - 1.013 bara (DIN 1343)

H250/RR - stainless steel, H250/HC - Hastelloy®

Measuring span:	10 : 1		
Flow values:	Values = 100%	Water: +20°C / +68°F	Air: +20°C / +68°F, 1.013 bara / 14.7 psia

		Water			Air			Max. pressure loss			
Float ▶		TIV	CIV	DIV	TIV Alu.	TIV	DIV	TIV Alu.	TIV	CIV	DIV
Nominal size	Cone	[GPH]			[SCFM]			[psig]			
DN15, 1/2"	K 15.1	4.76	6.60	-	0.26	0.40	-	0.18	0.31	0.38	-
	K 15.2	7.93	10.6	-	0.43	0.62	-	0.18	0.31	0.38	-
	K 15.3	14.5	16.6	-	0.62	0.93	-	0.18	0.31	0.38	-
	K 15.4	21.1	26.4	-	1.05	1.36	-	0.18	0.31	0.38	-
	K 15.5	31.7	42.3	-	1.55	2.23	-	0.18	0.31	0.38	-
	K 15.6	52.8	66.0	-	2.60	3.41	-	0.18	0.31	0.38	-
	K 15.7	92.5	106	185	4.15	6.20	11.2 ①	0.18	0.31	0.41	0.56
	K 15.8	132	166	264	6.20	8.68	17.4 ①	0.19	0.32	0.47	0.74
	K 15.8	-	-	423 ②	-	-	31.0 ②	-	-	-	1.25
DN25, 1"	K 25.1	127	166	264	5.89	8.68	-	0.16	0.35	0.47	1.06
	K 25.2	217	264	423	9.30	14.3	-	0.16	0.35	0.49	1.09
	K 25.3	317	423	660	13.6	21.7	-	0.16	0.37	0.50	1.10
	K 25.4	449	660	1057	22.9	31.0	68.2 ①	0.18	0.38	0.56	1.15
	K 25.5	845	1057	1664	38.4	58.9	111 ①	0.19	0.44	0.66	1.51 ③

① P > 7.4 psig

② with TR float

③ 4.4 psig with damping [gas measurement]

The operating pressure should be at least double the pressure loss for liquids and five times for gases. The indicated pressure losses are valid for water and air at maximum flow rate. Other flow ranges on request. Conversion of other media or operating data is performed using the calculation method in accordance with VDI/VDE directive 3513.

Reference condition for gas measurements:

Flow measurements for gases are attributed to SCFM or SCFH:

Volume flow at standard (std.) conditions 15°C - 1.013 bara (ISO 13443)

3.1 Intended use

Responsibility for the use of the measuring devices with regard to suitability, intended use and corrosion resistance of the used materials against the measured fluid lies solely with the operator.

This device is a Group 1, Class A device as specified within CISPR11:2009. It is intended for use in industrial environment. There may be potential difficulties in ensuring electromagnetic compatibility in other environments, due to conducted as well as radiated disturbances.

The manufacturer is not liable for any damage resulting from improper use or use for other than the intended purpose.

The variable area flowmeters are suitable for measuring clean gases, vapours and liquids.

Intended use:

- The product may not contain any ferromagnetic particles or solids. It may be necessary to install magnetic filters or mechanical filters.
- The product must be sufficiently liquid and free of deposits.
- Avoid pressure surges and pulsing flows.
- Open valves slowly. Do not use solenoid valves.

Use suitable measures to eliminate compression vibrations during gas measurements:

- Short pipeline lengths to next restriction
- Nominal pipe size not greater than nominal device size
- Use of floats with damping
- Increase in operating pressure (while taking into account the resulting change in density and thus change in scale)

Observe installation conditions according to VDI/VDE 3513-3.

For devices used in hazardous areas, additional safety notes apply; please refer to the Ex documentation.

Do not use any abrasive media containing solid particles or highly viscous media.

3.2 Installation conditions

When installing the device in the piping, the following points must be observed:

- *The variable area flowmeter must be installed vertically (measuring principle). Flow direction from bottom to top. For installation recommendations please refer also to directive VDI/VDE 3513, sheet 3.*
- *A straight unimpeded inlet run of ≥ 5 DN upstream of the device and a straight outlet run of ≥ 3 DN downstream of the device are recommended.*
- *Screws, bolts and gaskets are to be provided by the customer and must be selected in accordance with the pressure rating of the connection or the operating pressure.*
- *The inside diameter of the flange deviates from the standard dimensions.*
- *Align the gaskets. Tighten the nuts with the tightening torques of the appropriate pressure rating.*
- *Control devices are to be positioned downstream of the measuring device.*
- *Shutoff devices are preferably to be positioned upstream of the measuring device.*
- *Before connecting, blow or flush out the pipes leading to the device.*
- *Pipes for gas flow need to be dried before the device is installed.*
- *Use connectors suitable for the particular device version.*
- *Align the pipes centrically with the connection bores on the measuring device so they are free of stresses.*
- *If necessary, the piping has to be supported to reduce the vibrations transmitted to the measuring device.*
- *Do not lay signal cables directly next to cables for the power supply.*
- *The device must not be heated by radiated heat (e.g. exposure to the sun) to an electronics housing surface temperature above the maximum permissible ambient temperature. If it is necessary to prevent damage from heat sources, a heat protection (e.g. sun shade) has to be installed.*

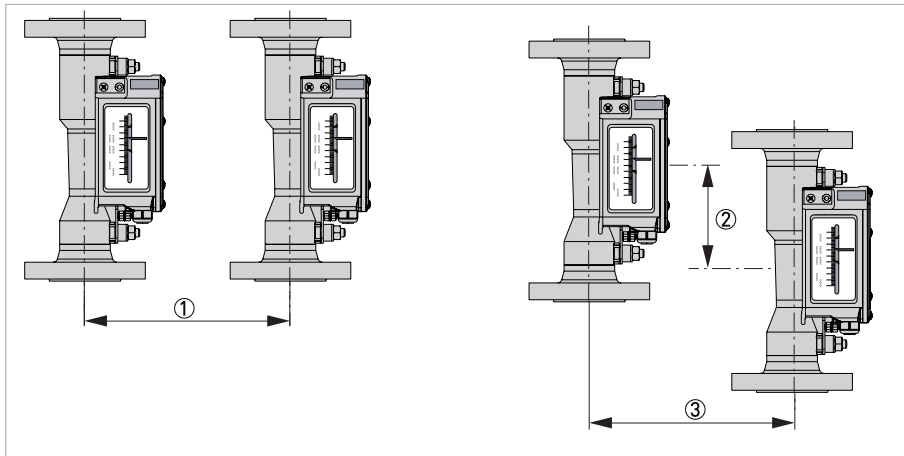

Figure 3-1: Minimum distance between devices (H250/M8MG)

- ① 180 mm / 7.1"
- ② 100 mm / 3.9"
- ③ 130 mm / 5.1"

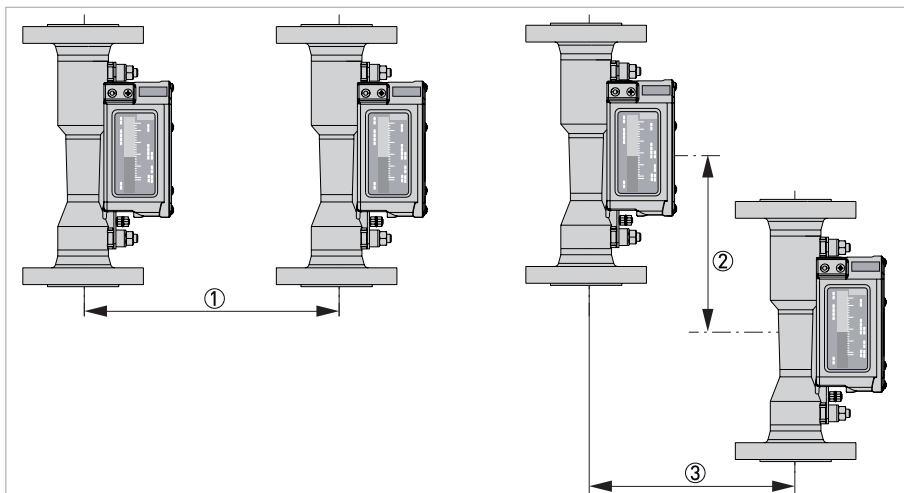

Figure 3-2: Minimum distance between devices (H250/M8EG)

- ① 250 mm / 9.8"
- ② 160 mm / 6.3"
- ③ 130 mm / 5.1"

3.2.1 Magnetic filters

The use of magnetic filters is recommended when the medium contains particles which can be influenced magnetically. The magnetic filter is to be installed in the flow direction upstream of the flowmeter. Bar magnets are positioned helically in the filter to provide optimal efficiency at low pressure loss. All of the magnets are coated individually with PTFE to protect against corrosion. Material: 1.4404 / 316L

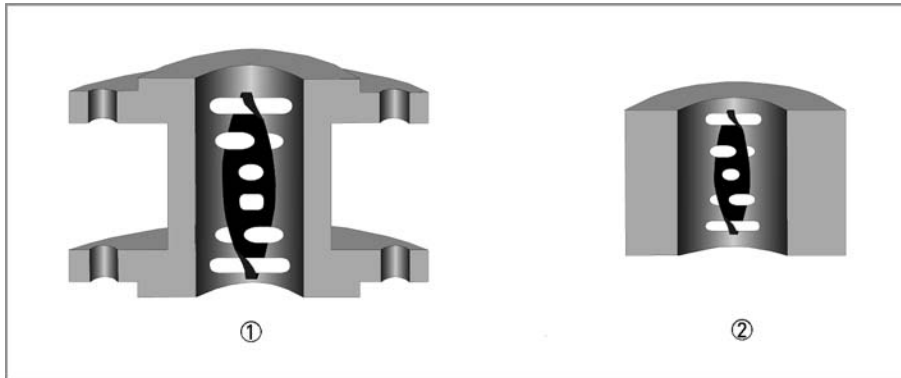

Figure 3-3: Types of magnetic filters

- ① Type F - fitting part with flange - overall length 100 mm / 4"
- ② Type FS - fitting part without flange - overall length 50 mm / 2"

4.1 Electrical connection procedure

For the electrical data of the used components refer to *Technical data* on page 6.

4.1.1 Indicator M8M - limit switches

The limit switches can be set over the entire measuring range using the maximum pointer ①. The set limit values are displayed on the scale. The pointers are set to the desired limit values using a slip coupling along the scale.

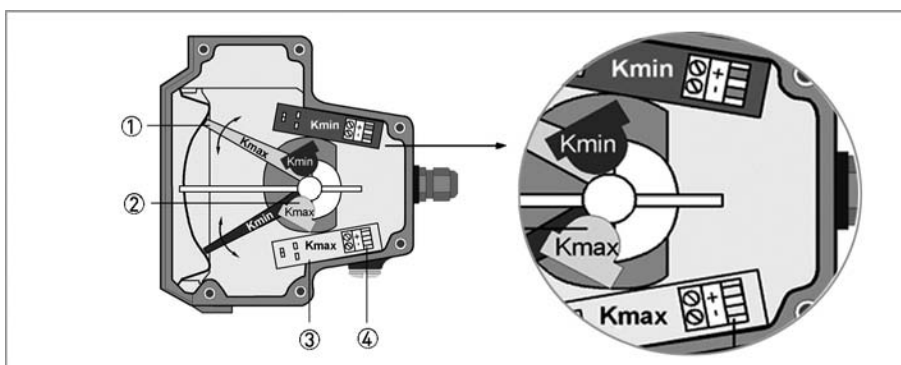

Figure 4-1: Limit switch settings M8MG

- ① Maximum pointer, switching point indicator
- ② Limit switches
- ③ Connection board
- ④ Connection terminal

4.1.2 Indicator M8E - current output

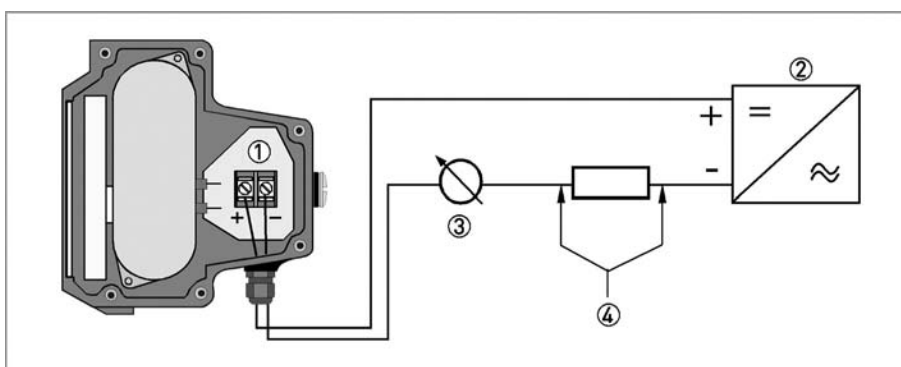

Figure 4-2: Electrical connection M8EG

- ① Terminal connection
- ② Power supply 14.8...30 VDC
- ③ Measuring signal 4...20 mA
- ④ External load, HART® communication

Power supply M8 with galvanic isolation

Wiring must be planned with great care when it comes to connecting other devices such as evaluation units or process control. Internal connections in these devices (e.g. GND with PE, mass loops) may lead to non-permitted voltage potentials which could negatively affect the function of the converter itself or that of a device connected to it. In such cases a protected extra-low voltage (PELV) is recommended.

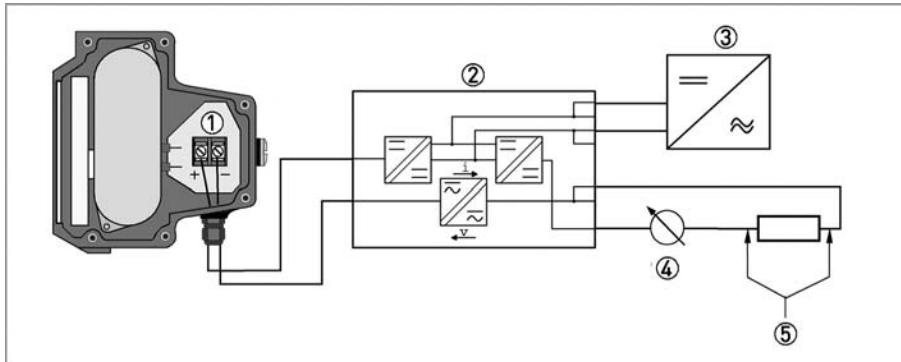

Figure 4-3: Electrical connection M8EG with electrical isolation

- ① Terminal connection
- ② Converter supply isolator with electrical isolation
- ③ Power supply (see supply isolator information)
- ④ Measuring signal 4...20 mA
- ⑤ External load, HART® communication

Power supply

The supply voltage has to be between 14.8 VDC and 30 VDC. This is based on the total resistance of the measuring loop. To calculate this, the resistance of each component in the measuring loop (not including the device) must be added together.

The required supply voltage can be calculated using the formula below:

$$U_{\text{ext.}} = R_L \cdot 22 \text{ mA} + 14.8 \text{ V}$$

with

$U_{\text{ext.}}$ = minimum supply voltage

R_L = total measuring loop resistance

The power supply has to be able to supply a minimum of 22 mA.

HART® communication

When HART® communication is carried out with the M8E indicator, the analogue measured data transmission (4...20 mA) is not impaired in any way.

Exception for multidrop operation. In multidrop operation a maximum of 15 devices with HART® function can be operated in parallel, whereby their current outputs are switched to inactive (I approx. 4 mA per device).

Load for HART® communication

For HART® communication a load of at least 230 Ω is required.

The maximum load resistance is calculated as follows:

$$R_L = \frac{U_{\text{ext.}} - 14,8V}{22 \text{ mA}}$$

Use a twisted two-core cable to prevent electrical interference from impeding the DC output signal.

In some cases a shielded cable may be necessary. The cable shield may only be grounded (common ground connection) at one point (on the power supply unit).

Configuration

The M8E electronic indicator can be configured via HART® communication. DD (Device Descriptions) for AMS 6.x and PDM 5.2 as well as a DTM (Device Type Manager) are available for configuration. They can be downloaded free of charge from the website of the manufacturer.

The current flow rate can be transmitted using the integrated HART® communication. A flow counter can be configured. Two limit values can be set and monitored. The limit values are assigned either to flow values or to the counter overflow. The limit values are not depicted on the display.

Please provide us with the missing information so that we can be of help to you as quickly as possible.

Then please fax this page to the appropriate sales associate. We will then contact you as soon as possible.

Device data

Connection type:			
Nominal connection size:			
Pressure rating:			
Raised face:			
Material of pipeline:			
Indicator:	<input type="checkbox"/> M8MG	<input type="checkbox"/> M8EG	
Indicator options:	<input type="checkbox"/> K1 ① <input type="checkbox"/> K2 ②		
Approval:	<input type="checkbox"/> None	<input type="checkbox"/> ATEX / IECEx	<input type="checkbox"/> QPS

① 1 limit switch

② 2 limit switches

Design data

Medium:			
Operating pressure:	<input type="checkbox"/> Absolute pressure	<input type="checkbox"/> Gauge pressure	
Rated pressure:			
Operating temperature:			
Rated temperature:			
Density:	<input type="checkbox"/> Standard density	<input type="checkbox"/> Operating density	
Viscosity:			
Flow range:			
Comments:			

Contact data

Company:	
Contact person:	
Telephone number:	
Fax number:	
E-mail:	

Алматы (7273)495-231
Ангарск (3955)60-70-56
Архангельск (8182)63-90-72
Астрахань (8512)99-46-04
Барнаул (3852)73-04-60
Белгород (4722)40-23-64
Благовещенск (4162)22-76-07
Брянск (4832)59-03-52
Владивосток (423)249-28-31
Владикавказ (8672)28-90-48
Владимир (4922)49-43-18
Волгоград (844)278-03-48
Вологда (8172)26-41-59
Воронеж (473)204-51-73
Екатеринбург (343)384-55-89
Иваново (4932)77-34-06
Ижевск (3412)26-03-58
Иркутск (395)279-98-46
Казань (843)206-01-48

Калининград (4012)72-03-81
Калуга (4842)92-23-67
Кемерово (3842)65-04-62
Киров (8332)68-02-04
Коломна (4966)23-41-49
Кострома (4942)77-07-48
Краснодар (861)203-40-90
Красноярск (391)204-63-61
Курган (3522)50-90-47
Курск (4712)77-13-04
Липецк (4742)52-20-81
Магнитогорск (3519)55-03-13
Москва (495)268-04-70
Мурманск (8152)59-64-93
Набережные Челны (8552)20-53-41
Нижний Новгород (831)429-08-12
Новокузнецк (3843)20-46-81
Новосибирск (383)227-86-73
Ноябрьск(3496)41-32-12

Омск (3812)21-46-40
Орел (4862)44-53-42
Оренбург (3532)37-68-04
Пенза (8412)22-31-16
Пермь (342)205-81-47
Петрозаводск (8142)55-98-37
Псков (8112)59-10-37
Ростов-на-Дону (863)308-18-15
Рязань (4912)46-61-64
Самара (846)206-03-16
Санкт-Петербург (812)309-46-40
Саранск (8342)22-96-24
Саратов (845)249-38-78
Севастополь (8692)22-31-93
Симферополь (3652)67-13-56
Смоленск (4812)29-41-54
Сочи (862)225-72-31
Ставрополь (8652)20-65-13
Сургут (3462)77-98-35

Сыктывкар (8212)25-95-17
Тамбов (4752)50-40-97
Тверь (4822)63-31-35
Тольятти (8482)63-91-07
Томск (3822)98-41-53
Тула (4872)33-79-87
Тюмень (3452)66-21-18
Улан-Удэ (3012)59-97-51
Ульяновск (8422)24-23-59
Уфа (347)229-48-12
Хабаровск (4212)92-98-04
Чебоксары (8352)28-53-07
Челябинск (351)202-03-61
Череповец (8202)49-02-64
Чита (3022)38-34-83
Якутск (4112)23-90-97
Ярославль (4852)69-52-93

Россия +7(495)268-04-70

Казахстан +7(7172)727-132

Киргизия +996(312)96-26-47

<https://opti.nt-rt.ru> || opti@nt-rt.ru