

Алматы (7273)495-231
Ангарск (3955)60-70-56
Архангельск (8182)63-90-72
Астрахань (8512)99-46-04
Барнаул (3852)73-04-60
Белгород (4722)40-23-64
Благовещенск (4162)22-76-07
Брянск (4832)59-03-52
Владивосток (423)249-28-31
Владикавказ (8672)28-90-48
Владимир (4922)49-43-18
Волгоград (844)278-03-48
Вологда (8172)26-41-59
Воронеж (473)204-51-73
Екатеринбург (343)384-55-89
Иваново (4932)77-34-06
Ижевск (3412)26-03-58
Иркутск (395)279-98-46
Казань (843)206-01-48

Калининград (4012)72-03-81
Калуга (4842)92-23-67
Кемерово (3842)65-04-62
Киров (8332)68-02-04
Коломна (4966)23-41-49
Кострома (4942)77-07-48
Краснодар (861)203-40-90
Красноярск (391)204-63-61
Курган (3522)50-90-47
Курск (4712)77-13-04
Липецк (4742)52-20-81
Магнитогорск (3519)55-03-13
Москва (495)268-04-70
Мурманск (8152)59-64-93
Набережные Челны (8552)20-53-41
Нижний Новгород (831)429-08-12
Новокузнецк (3843)20-46-81
Новосибирск (383)227-86-73
Ноябрьск(3496)41-32-12

Омск (3812)21-46-40
Орел (4862)44-53-42
Оренбург (3532)37-68-04
Пенза (8412)22-31-16
Пермь (342)205-81-47
Петрозаводск (8142)55-98-37
Псков (8112)59-10-37
Ростов-на-Дону (863)308-18-15
Рязань (4912)46-61-64
Самара (846)206-03-16
Санкт-Петербург (812)309-46-40
Саранск (8342)22-96-24
Саратов (845)249-38-78
Севастополь (8692)22-31-93
Симферополь (3652)67-13-56
Смоленск (4812)29-41-54
Сочи (862)225-72-31
Ставрополь (8652)20-65-13
Сургут (3462)77-98-35

Сыктывкар (8212)25-95-17
Тамбов (4752)50-40-97
Тверь (4822)63-31-35
Тольятти (8482)63-91-07
Томск (3822)98-41-53
Тула (4872)33-79-87
Тюмень (3452)66-21-18
Улан-Удэ (3012)59-97-51
Ульяновск (8422)24-23-59
Уфа (347)229-48-12
Хабаровск (4212)92-98-04
Чебоксары (8352)28-53-07
Челябинск (351)202-03-61
Череповец (8202)49-02-64
Чита (3022)38-34-83
Якутск (4112)23-90-97
Ярославль (4852)69-52-93

Россия +7(495)268-04-70

Казахстан +7(7172)727-132

Киргизия +996(312)96-26-47

<https://opti.nt-rt.ru> || opti@nt-rt.ru

УРОВНЕМЕРЫ

BM 702

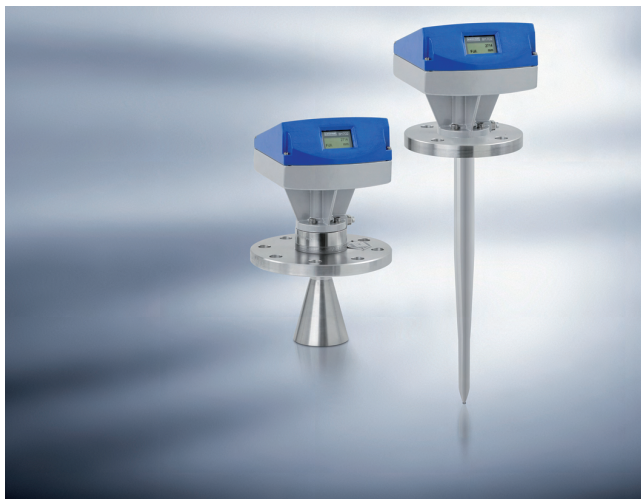

1.1 The 2-wire radar solution

This device is a non-contact Radar (FMCW) level meter for distance, level and volume measurement of liquids, pastes and slurries. It gives a more robust and reliable measurement than pulse radar systems and is well suited to agitated process conditions.

The device can operate at process temperatures up to +250°C / +480°F if a version with HT (high-temperature) distances pieces is ordered.

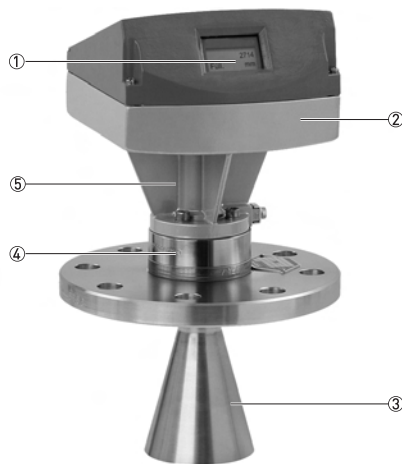

(Horn antenna version)

- ① Optional display with 4 key operation
- ② 2-wire FMCW radar level meter
- ③ Metallic horn antenna in various materials (antenna extensions for long nozzles available)
- ④ Metaglas® barrier
- ⑤ Rotatable housing (90° steps)

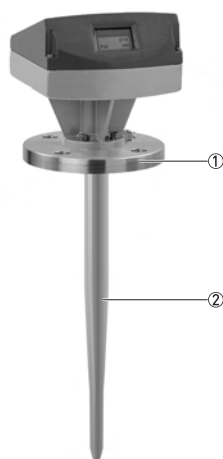

(Wave-Stick version)

- ① Flange connection, optional threaded and hygienic connections
- ② Wave-Stick antenna (PP or PTFE)

Highlights

- Reliable measurement in difficult process conditions
- Measuring range up to 30 m / 98 ft (dep. on antenna version)
- Modular design allows the replacement of the converter under process conditions (without interruption of the process)
- Operates up to flange temperature of +250°C / +480°F and pressure of 1000 bar / 14504 psi
- Wave-Stick antenna for corrosive liquids (with optional PP/PTFE flange plate) and hygienic applications
- A variety of operating languages integrated as standard for the optionally equipped graphical display
- Antenna extension available to suit any nozzle length (straight, 90° bent and S-shaped)
- Purging system for cleaning, heating or cooling of antenna as option available
- ± 10 mm / 0.4" standard accuracy, optional ± 5 mm / 0.2"
- Excellent price/performance ratio

Industries

- Chemicals
- Food & Beverage
- Oil & Gas
- Petrochemicals
- Pulp & Paper
- Water & Wastewater

Applications

- Storage tanks
- Process tanks
- Stilling wells and bypass chambers

1.2 Applications

1. Level measurement of liquids in storage tanks

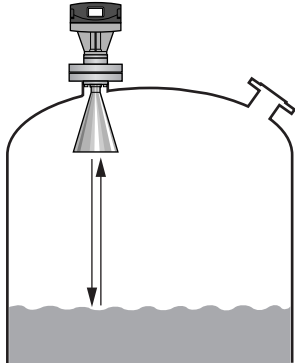

The level transmitter can measure the level of a wide range of liquid products on a large variety of installations, including LPG and LNG tanks. It does not require calibration or commissioning when installed. It can measure nearly any liquid within the stated pressure and temperature range, and distances up to 30 m / 98 ft.

2. Level measurement of liquids in process tanks

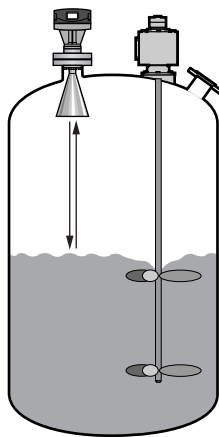

The level transmitter can measure level accurately under process conditions, such as near to vortices caused by small agitators, and also where foam is present.

3. Level measurement in horizontal cylinders and spherical tanks

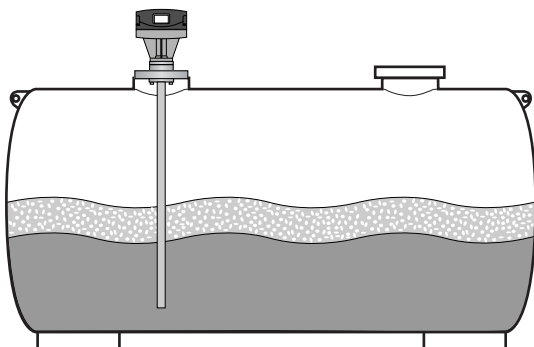

BM 702 A is able to measure the level in horizontal cylinders and spherical tanks. In this case the use of a stilling well or a Wave-Guide antenna is positively recommended to avoid multiple reflections.

4. Measurement of liquids in a bypass chamber

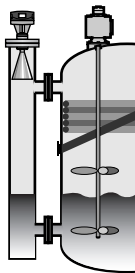

If the tank is full of obstructions such as agitators and reinforcements, we recommend installing the radar level transmitter in a bypass chamber or a stilling well. This solution is also available from us under the name BM 26 W. The BM 26 W combines the BM 26 A with the radar level transmitter. The device includes a permanent, local indication without a power supply. Please refer to the BM 26 W documentation for further information.

5. Measurement of corrosive liquids with a Wave-Stick antenna

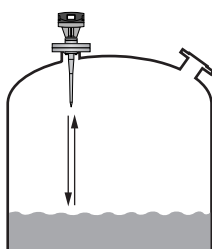

The Wave-Stick antenna option combines a relatively small radar beam for more precise measurement and a shape that avoids product build-up. If the tank contains corrosive liquids such as acids and alkaline solutions, we recommend the Wave-Stick antenna with the PTFE or PP flange plate option.

6. Measurement with curved antenna extensions for difficult applications

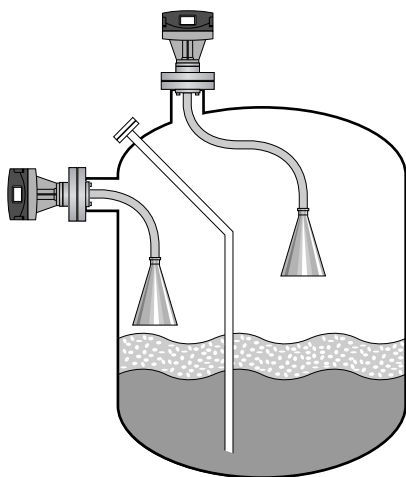

Rectangular and S-shaped antenna extensions are available for particularly difficult application conditions. These extensions are used in cases where the antenna is exposed to high temperatures and where there are problems with space (e.g. around tank internals; positioning the antenna out of the centre of symmetry; mounting the signal converter on the side of the tank).

1.3 Measuring principle

A radar signal is emitted via an antenna, reflected on the product surface and received after a time t . The radar principle used is FMCW (Frequency Modulated Continuous Wave).

The FMCW-radar transmits a high frequency signal whose frequency increases linearly during the measurement phase (called the frequency sweep). The signal is emitted, reflected on the measuring surface and received with a time delay, t . Delay time, $t=2d/c$, where d is the distance to the product surface and c is the speed of light in the gas above the product.

For further signal processing the difference Δf is calculated from the actual transmit frequency and the receive frequency. The difference is directly proportional to the distance. A large frequency difference corresponds to a large distance and vice versa. The frequency difference Δf is transformed via a Fourier transformation (FFT) into a frequency spectrum and then the distance is calculated from the spectrum. The level results from the difference between tank height and measuring distance.

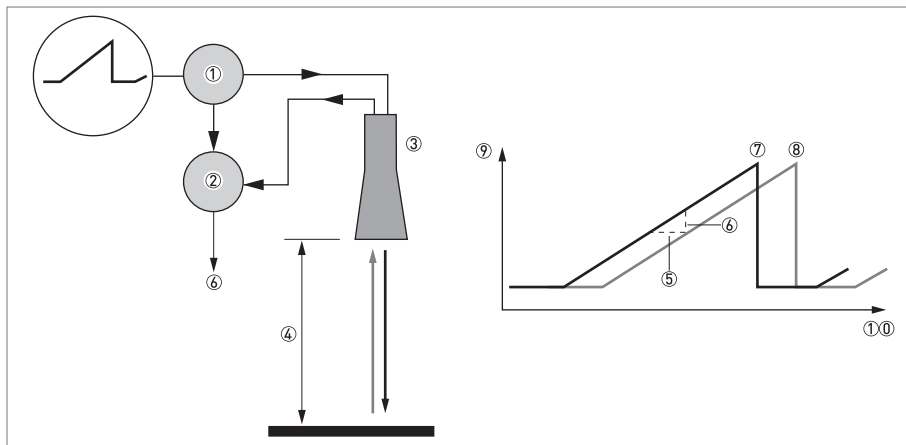

Figure 1-1: Measuring principle of FMCW radar

- ① Transmitter
- ② Mixer
- ③ Antenna
- ④ Distance to product surface, where change in frequency is proportional to distance
- ⑤ Differential time delay, Δt
- ⑥ Differential frequency, Δf
- ⑦ Frequency transmitted
- ⑧ Frequency received
- ⑨ Frequency
- ⑩ Time

2.1 Technical data

- *The following data is provided for general applications. If you require data that is more relevant to your specific application, please contact us or your local representative.*
- *Additional information (certificates, special tools, software,...) and complete product documentation can be downloaded free of charge from the website (Downloadcenter).*

Measuring system

Measuring principle	2-wire loop-powered level transmitter; X-band FMCW radar
Application range	Level measurement of liquids, pastes and slurries
Primary measured value	Δf (change in frequency) between the emitted and received signal
Secondary measured value	Distance, level, volume and reflectivity

Design

Construction	The measurement system consists of a measuring sensor (horn or Wave-Stick antenna) and a signal converter which is available in a compact version.
Options	Integrated graphical display
	High-temperature version (max. +250°C / +480°F, dep. on used gaskets)
	Special version (with Silicone/FEP gaskets) for low temperatures (min. -60°C / -76°F)
	Version for food application with dairy screw or Tri-clamp connection
	Antenna purging system for horn antenna (supplied with ¼ NPTF connection)
	Wave-Guide antenna
	Wave-Stick: PTFE or PP flange plate
Accessories	Heated or cooled antenna for sticky products or high-temperature applications
	Weather protection
Max. measuring range	Antenna extensions of 100 mm / 3.9" length; 90° bent; S-shaped
	30 m / 98 ft
Min. tank height	Depends on the antenna option, dielectric constant of the product and installation type. Refer also to "Antenna selection".
	0.5 m / 19.7"
Min. block distance	0.2...0.5 m / 0.7...1.6 ft
Beam angle of antenna	Horn DN80 / 3", type 1: 16°
	Horn DN100 / 4", type 2: 12°
	Horn DN150 / 6", type 3: 8°
	Horn DN200 / 8", type 4: 6°
	Wave-Stick 25 mm / 1": 9°
	Wave-Guide / stilling well 25...200 mm / 1...8": Propagation only inside the stilling well
Display and user interface	
Display	Graphical display (64 x 128 pixels)
Interface languages	English, German, French, Italian, Spanish, Portuguese, Swedish
Measurement units	Lengths: m, cm, mm, inch, ft, %, free unit (customer defined) Volume: m ³ , Liter, US Gal, GB Gal, ft ³ , bbl, free unit (customer defined)

Measuring accuracy

Resolution	1 mm / 0.04"
Repeatability	≤ 0.5 x measuring error
Accuracy	Standard: ±10 mm / ±0.4", when distance ≤ 5 m / 16.4 ft or ±0.2% of measured distance, when distance > 5 m / 16.4 ft
	Option: ±5 mm / ±0.2", when distance ≤ 5 m / 16.4 ft or ±0.1% of measured distance, when distance > 5 m / 16.4 ft
Reference conditions acc. to EN 60770	
Temperature	+20°C ±5°C / +70°F ±10°F
Pressure	1013 mbar abs. ±20 mbar / 14.69 psig ±0.29 psig
Relative air humidity	60% ±15%
Target	Metal plate in an anechoic chamber

Operating conditions

Temperature	
Ambient temperature	-20...+55°C / -4...+130°F Functional range: -40...+70°C / -40...+160°F
Storage temperature	-40...+85°C / -40...+185°F
Process connection temperature	V96 flange system with horn antenna or Wave-Guide: Standard without HT distance piece (K6375 gasket): -20...+130°C / -5...+260°F (depending on the temperature limits of the gasket material. For other gasket materials see "Materials" in this table.) With HT distance piece (K6375 gasket): -20...+250°C / -5...+260°F (depending on the temperature limits of the gasket material. For other gasket materials see "Materials" in this table.)
	LP flange system with horn antenna or Wave-Guide: -20...+130°C / -4...+266°F (only available without HT distance piece)
	Wave-Stick: PTFE with or without flange plate: -20...+130°C / -5...+260°F (dep. on flange size and pressure rating. Refer to chapter "Pressure ratings".) PTFE with or without flange plate and HT distance piece: -20...+150°C / -5...+300°F (dep. on flange size and pressure rating. Refer to chapter "Pressure ratings".) PP without flange plate: -20...+100°C / -5...+210°F (only available without HT distance piece)
Thermal shock resistance	<40°C/s / <72°F/s
Pressure	
Operating pressure	V96 flange system with horn antenna or Wave-Guide: -1...40 bar / -14.5...580 psig (dep. on flange size and pressure rating. Refer to chapter "Pressure ratings".) Higher pressures on request.
	LP flange system with horn antenna, Wave-Guide or Wave-Stick without flange plate: -1...2 bar / -14.5...29 psig
	Wave-Stick with flange plate: -1...16 bar / -14.5...232 psig (dep. on temperature; Refer to chapter "Pressure ratings".)

Other conditions	
Physical properties	No effect on measurement results; for reliable measurements the relative permittivity should have the following values:
Dielectric constant (ϵ_r)	$\epsilon_r \geq 1.5$;
	$\epsilon_r < 3$: stilling well recommended;
	Wave-Stick immersed: $\epsilon_r \geq 4$
Product limitations	Liquid ammonia (NH ₃), liquid hydrogen (H ₂), liquid helium (He)
Vibration resistance	IEC 60068-2-6 and EN 50178 (10...57 Hz: 0.075 mm / 57...150 Hz:1g)
Protection category	IP66/67 equivalent to NEMA 6-6X

Installation conditions

Installation requirement	For detailed information refer to chapter "Installation".
Process connection position	Make sure that there are not any obstructions directly below the process connection for the device.
Dimensions and weights	For detailed information refer to chapter "Dimensions and weights".

Materials

Signal converter housing	Aluminium with electrostatic powder coating
	Sight window: glass
Flange system (V96 and LP), antenna, antenna extension	Standard: Stainless Steel (1.4571 / 316 Ti)
	Option: Stainless Steel (1.4435 / 316 L), Hastelloy® C4 or B2, Titanium, Tantalum
	Information on other materials on request.
Wave-Stick	Flanges: Stainless Steel (1.4571 / 316 Ti)
	Flange plate: PP or PTFE
Gaskets	K4079 without HT distance piece: -20...+130°C / -5...+260°F K4079 with HT distance piece: -20...+250°C / -5...+480°F
	K2035 without HT distance piece: -20...+130°C / -5...+260°F K2035 with HT distance piece: -20...+210°C / -5...+410°F
	K6230 without HT distance piece: -20...+130°C / -5...+260°F K6230 with HT distance piece: -20...+210°C / -5...+410°F
	K6375 without HT distance piece: -20...+130°C / -5...+260°F K6375 with HT distance piece: -20...+250°C / -5...+480°F
	FPM without HT distance piece: -20...+130°C / -5...+260°F FPM with HT distance piece: -20...+200°C / -5...+390°F
	FPM/FEP without HT distance piece: -15...+130°C / +5...+260°F FPM/FEP with HT distance piece: -15...+200°C / +5...+390°F
	Silicone/FEP without HT distance piece: -30...+130°C / -20...+260°F Silicone/FEP with HT distance piece: -30...+200°C / -20...+390°F Special version: -60...+130°C / -75...+260°F
	PFA without HT distance piece: -30...+130°C / -20...+260°F PFA with HT distance piece: -30...+200°C / -20...+390°F
Weather protection (Option)	Stainless Steel (1.4301 / 304)

Process connections

Horn antenna or Wave-Guide	DN50...200, PN6...64 ASME B16.5: 2...8", 150/300 lbs/RF
Wave-Stick	DN50...150 ASME B16.5: 2...6", G1½, 1½NPT
Dairy screw connection	DIN 11851: DN50, DN65, DN80 SMS 1145: 51 mm, 63 mm, 76 mm
Tri-clamp	ISO 2852: 2...4"

Electrical connections

Power supply	Non-Ex / Ex i: 14.5...30 VDC
Cable entry	M20x1.5; ½NPT G½
Cable gland	Standard: M20x1.5 Options: ½NPT, G½ adapter
Cable entry capacity (terminal)	0.5...1.5 mm ² / AWG 20...16
U-clamp terminals (for PA and FE)	Max. 4 mm ² / AWG 12

Output

Description of the used abbreviations	U_{ext} = external voltage; R_L = load + resistance
Current output	
Output data	Distance, level, volume and reflectivity
Measuring range	4...20 mA HART® or 3.8...20.5 mA acc. to NAMUR NE 43 ①
Load	Minimal 0 Ω; max. $R_L = ((U_{\text{ext.}} - 14.5 \text{ VDC}) / 22 \text{ mA})$
Temperature drift	≤ 150 ppm/K
Error signal	Acc. to NAMUR NE 43 High value: 22 mA Low value: 3.6 mA
HART®	
Description	HART® protocol via current output HART® version: V5
Load	≥ 250 Ω at HART® test point; Note maximum load for current output!
Multidrop operation	Yes, current output = 4 mA Multidrop address adjustable in operation menu 1...15

Approvals and certifications

CE	This device fulfils the statutory requirements of the EC directives. The manufacturer certifies successful testing of the product by applying the CE marking.
ATEX	ATEX II 1/2 G Ex ia IIC T6...T1
Other standards and approvals	
EMC	EMC Directives 2004 / 108 / EC and 93 / 68 / EEC in conjunction with EN 61326-1 (2006).
LVD	Low-Voltage Directives 2006 / 95 / EC and 93 / 68 / EEC in conjunction with EN 61010-1 (2001).
NAMUR	NAMUR NE 21 Electromagnetic Compatibility (EMC) of Industrial Process and Laboratory Control Equipment
	NAMUR NE 43 Standardization of the Signal Level for the Failure Information of Digital Transmitters

① HART® is a registered trademark of the HART Communication Foundation.

2.2 Pressure ratings

V96 flange system with horn antenna or Wave-Guide:
max. allowable operating pressure

Nominal diameter		Flange rated pressure							
		PN16		PN25		PN40		PN64	
DN	inches	bar	psig	bar	psig	bar	psig	bar	psig
80	3	16	232	-	-	40	580	64	928
100	4	16	232	-	-	38	551	55	797
150	6	16	232	-	-	34	493	47	681
200	8	16	232	25	362	32	464	45	652

Wave-Stick with flange plate: pressure / temperature rating

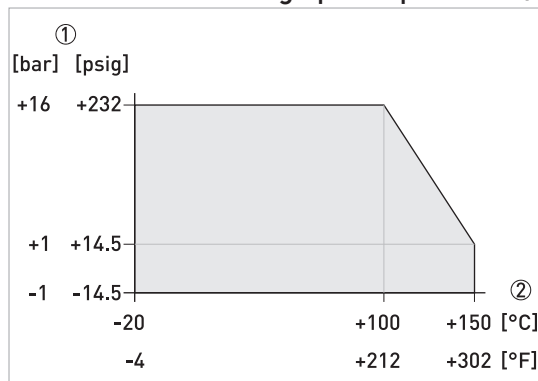

- ① Pressure in [bar] or [psig]
- ② Temperature in [°C] or [°F]

2.3 Antenna selection

The graph below shows which antenna to select for the application.

Graph of tank height / measuring range against dielectric constant ϵ_r

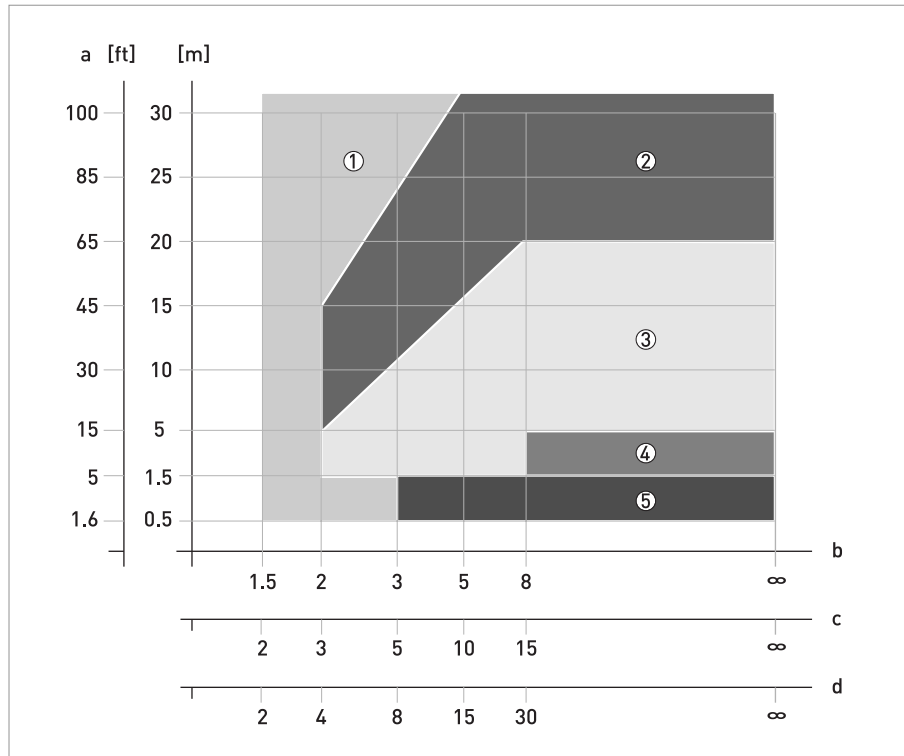

Figure 2-1: Selection of antenna

a = tank height / measuring range [ft / m]

b = ϵ_r for storage tanks with smooth product surface

c = ϵ_r for process tanks or foam

d = ϵ_r for agitator tanks with vortex

- ① Stilling well* (not for agitator tanks)
- ② Stilling well* (not for agitator tanks) or antenna type 4
- ③ Stilling well* (not for agitator tanks); Wave-Stick or antenna type 3 and type 4
- ④ Stilling well* (not for agitator tanks); antenna type 2, type 3 and type 4 or Wave-Stick
- ⑤ Stilling well* (not for agitator tanks) or Wave-Stick

* Stilling well is equal to Wave-Guide antenna and bypass chamber

2.4 Dimensions

Horn antenna	High-temperature version
b = 215 mm / 8.5"	a = 355 mm / 14"
c = 155 mm / 6.1"	
e = 198 mm / 7.8"	
f = 172 mm / 6.8"	
For dimensions of a and Ød, see table below.	

Nominal size		Antenna	Dimensions [mm]				Approx. weight
DN [mm]	ASME [inches]	Type	Ød	a (SS 1.4571/ SS 316 Ti)	a (Hastelloy® C4)	a (Titanium, Tantalum)	[kg]
80	3	1	80	110	145	110	9
100	4	2	100	148	177	146	10
150	6	3	140	223	250	220	16
200	8	4	200	335	360	332	21

Nominal size		Antenna	Dimensions [inches]				Approx. weight
DN [mm]	ASME [inches]	Type	Ød	a (SS 1.4571/ SS 316 Ti)	a (Hastelloy® C4)	a (Titanium, Tantalum)	[lbs]
80	3	1	3.15	4.33	5.71	4.33	20
100	4	2	3.94	5.83	6.97	5.75	22
150	6	3	5.51	8.78	9.84	8.66	35
200	8	4	7.87	13.19	14.17	13.07	46

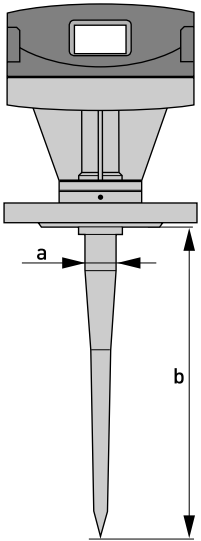
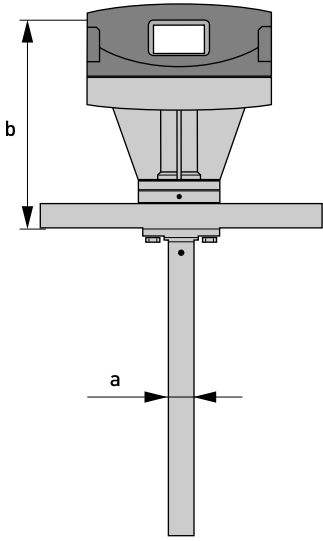
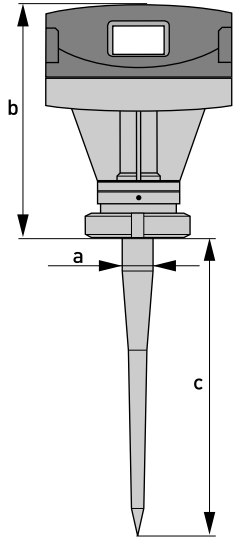
Wave-Stick	Wave-Guide	Wave-Stick Dairy screw connection
		
<p>a = Ø25 mm / Ø1.0"</p>	<p>a = Ø30 mm / Ø1.2"</p>	<p>a = Ø25 mm / Ø1.0"</p>
<p>b = ≥270 mm / 10.6"</p>	<p>b = 215 mm / 8.5"</p>	<p>b = 205 mm / 8.1"</p>
		<p>c = ≥270 mm / 10.6"</p>
<p>Weight: approx. 6 kg / 13.2 lbs (DN50)</p>	<p>Weight: approx. 7 kg / 15.4 lbs (DN50, 1 m / 3.9")</p>	<p>Weight: approx. 4.4 kg / 8.8 lbs</p>

Алматы (7273)495-231
Ангарск (3955)60-70-56
Архангельск (8182)63-90-72
Астрахань (8512)99-46-04
Барнаул (3852)73-04-60
Белгород (4722)40-23-64
Благовещенск (4162)22-76-07
Брянск (4832)59-03-52
Владивосток (423)249-28-31
Владикавказ (8672)28-90-48
Владимир (4922)49-43-18
Волгоград (844)278-03-48
Вологда (8172)26-41-59
Воронеж (473)204-51-73
Екатеринбург (343)384-55-89
Иваново (4932)77-34-06
Ижевск (3412)26-03-58
Иркутск (395)279-98-46
Казань (843)206-01-48

Калининград (4012)72-03-81
Калуга (4842)92-23-67
Кемерово (3842)65-04-62
Киров (8332)68-02-04
Коломна (4966)23-41-49
Кострома (4942)77-07-48
Краснодар (861)203-40-90
Красноярск (391)204-63-61
Курган (3522)50-90-47
Курск (4712)77-13-04
Липецк (4742)52-20-81
Магнитогорск (3519)55-03-13
Москва (495)268-04-70
Мурманск (8152)59-64-93
Набережные Челны (8552)20-53-41
Нижний Новгород (831)429-08-12
Новокузнецк (3843)20-46-81
Новосибирск (383)227-86-73
Ноябрьск(3496)41-32-12

Омск (3812)21-46-40
Орел (4862)44-53-42
Оренбург (3532)37-68-04
Пенза (8412)22-31-16
Пермь (342)205-81-47
Петрозаводск (8142)55-98-37
Псков (8112)59-10-37
Ростов-на-Дону (863)308-18-15
Рязань (4912)46-61-64
Самара (846)206-03-16
Санкт-Петербург (812)309-46-40
Саранск (8342)22-96-24
Саратов (845)249-38-78
Севастополь (8692)22-31-93
Симферополь (3652)67-13-56
Смоленск (4812)29-41-54
Сочи (862)225-72-31
Ставрополь (8652)20-65-13
Сургут (3462)77-98-35

Сыктывкар (8212)25-95-17
Тамбов (4752)50-40-97
Тверь (4822)63-31-35
Тольятти (8482)63-91-07
Томск (3822)98-41-53
Тула (4872)33-79-87
Тюмень (3452)66-21-18
Улан-Удэ (3012)59-97-51
Ульяновск (8422)24-23-59
Уфа (347)229-48-12
Хабаровск (4212)92-98-04
Чебоксары (8352)28-53-07
Челябинск (351)202-03-61
Череповец (8202)49-02-64
Чита (3022)38-34-83
Якутск (4112)23-90-97
Ярославль (4852)69-52-93

Россия +7(495)268-04-70

Казахстан +7(7172)727-132

Киргизия +996(312)96-26-47

<https://opti.nt-rt.ru> || opti@nt-rt.ru